



HASSIBA BENBOUALI UNIVERSITY

CHLEF

Faculty of Technology

Electronics Department

MASTER DISSERTATION

Field: SCIENCE AND TECHNOLOGY
Sector: TELECOMMUNICATIONS
Specialization: TELECOMMUNICATIONS SYSTEMS

TTC antenna at S-band for the drone to Geo satellite application.

By

MANSOUR BOKHTACHE Rofaida
ADDAOUI Narimane

Supervisor:

M. KOURDI Zakarya

Associate Professor «A» at CDS-Oran

Co- Supervisor:

Mss. FOUR Imane

Associate Professor «B» at l'UHBC

Chlef, 25 June 2024



THANKS

First of all, a word of praise, thanks and gratitude to Almighty God, who has guided us on the right path throughout this work and inspired us with the right steps and the right reflexes.

Without His mercy, this work would not have been could not have been achieved. Our sincere thanks go to our supervisor. Mr. **Zakarya KOURDI**, Senior Researcher at the Satellite Development Center in Oran, who put all his expertise at our disposal, for his judicious advice and his regular support in the elaboration of this modest work.

We would also like to thank our co-supervisor, Mss. **Imane FOUR**, assistant professor at the University of Chlef, for agreeing to supervise our work, her contributions and remarks have enabled us to correct and finalize this work to the best of our ability.

We would like to express our gratitude to the members of the jury who kindly devoted their time to the examination and study of our work.

We would also like to extend our warmest thanks to all the members of the Department of Electronics at the University of Chlef, who gave us such a warm welcome.

DEDICATION

We dedicate this modest work:

TO MY PARENTS: ALHADJE AND GAMILA

***THANKS TO THEIR TENDER ENCOURAGEMENT AND GREAT
SACRIFICES***

NO DEDICATION COULD EXPRESS MY RESPECT, CONSIDERATION

CONSIDERATION AND MY DEEP FEELINGS TOWARDS THEM.

***I PRAY THE GOOD GOD TO BLESS THEM, IN THE HOPE THAT THEY
WILL ALWAYS BE Proud OF ME.***

To my only brother: YOUNASS

My friend and support

***I hope that God will make things easier for him, because I want to see him at
his peak***

And my sisters: SAMIA, RAHAF and LOJAINÉ

To those who have contributed near or far to the outcome of this work.

To my dear binome: NARIMANE

To my dear friends BADRA, IKRAM for their support.

***To my aunts, thank you for encouraging me to continue my career without
giving up***

To all our loved ones,

ROFAIDA

Dedication

I dedicate this thesis

To my dear OUDA Your prayers and blessings have been a great help to me in my studies. I dedicate this work to you as a token of my deep love. May God, the Almighty, preserve you and grant your health and long life.

To my brothers: MOHAMED, AYMEN and ISSAM

And finally, to my partner, ROFAIDA, for all her hard work and encouragement.

To all those who have supported and encouraged me.

To all my teachers since my first years of study.

Narimane

Résumé : Ce travail porte sur la conception et la mise en œuvre d'un système d'antenne de télémétrie, de suivi et de contrôle (TTC) en bande S permettant d'établir une liaison de communication entre un drone et un satellite géostationnaire (GEO). L'étude examine les paramètres critiques impliqués dans le processus de conception de l'antenne, notamment le type d'antenne, le gain, la largeur du faisceau et la polarisation. La recherche souligne l'importance d'une analyse méticuleuse du bilan de liaison pour déterminer les facteurs essentiels tels que la puissance de l'émetteur, la sensibilité du récepteur et la perte de trajet, garantissant une liaison de communication fiable. La simulation s'effectue avec le logiciel CST Studio Tools. De plus, l'étude explore les technologies des systèmes de suivi, en considérant à la fois les cardans mécaniques et les antennes réseau à commande électronique, pour maintenir l'alignement avec le satellite Geo. Les facteurs environnementaux sont également pris en compte pour optimiser les performances du système d'antenne dans diverses conditions.

Mot clé : TTC, S-band, Drone, Satellite, Intercommunication, GEO, CST.

Abstract: This work focuses on the design and implementation of an S-band Telemetry, Tracking, and Control (TTC) antenna system for establishing a communication link between a drone and a geostationary (GEO) satellite. The study investigates the critical parameters involved in the antenna design process, including antenna type, gain, beamwidth, and polarization. The research emphasizes the significance of a meticulous link budget analysis to determine the essential factors such as transmitter power, receiver sensitivity, and path loss, ensuring a reliable communication link. The simulation is with CST Studio Tools software. Additionally, the study explores tracking system technologies, considering both mechanical gimbals and electronically steered phased array antennas, to maintain alignment with the Geo satellite. Environmental factors are also considered to optimize the antenna system's performance under varying conditions.

Keyword: TTC, S-band, Drone, Satellite, Intercommunication, GEO, CST.

تلخيص: يركز هذا العمل على تصميم وتنفيذ نظام هوائي للقياس عن بعد والتتبع والتحكم (TTC) على النطاق S لإنشاء رابط اتصال بين طائرة بدون طيار وقمر صناعي مستقر بالنسبة إلى الأرض (GEO). تبحث الدراسة في المعلمات الحرجة المشاركة في عملية تصميم الهوائي، بما في ذلك نوع الهوائي والكسب وعرض الحزمة والاستقطاب. يؤكد البحث على أهمية التحليل الدقيق لميزانية الارتباط لتحديد العوامل الأساسية مثل قوة المرسل، وحساسية المستقبل، وفقدان المسار، مما يضمن وجود رابط اتصال موثوق. تتم المحاكاة باستخدام برنامج CST Studio Tools. بالإضافة إلى ذلك، تستكشف الدراسة تقنيات نظام التتبع، مع الأخذ في الاعتبار كلاً من المحاور الميكانيكية والهوائيات الطورية الموجهة إلكترونياً، للحفاظ على التوافق مع القمر الصناعي الجغرافي. يتم أيضاً أخذ العوامل البيئية في الاعتبار لتحسين أداء نظام الهوائي في ظل ظروف مختلفة.

الكلمة المفتاحية: TTC، S-band، الطائرة بدون طيار، الأقمار الصناعية، الاتصالات البينية، GEO، CST.

CONTENTS

CONTENTS

<i>Thanks</i>	I
<i>Dedication</i>	II
Abstract:	IV
Acronyms and Abbreviations	IX
List of figures	XI
List of tables	XIII
General Introduction.....	1
Chapter I: General Information On Patch Antennas	4
I. Introduction	4
II. Characteristics of the antennas.....	4
II-1. Directivity	5
II-2. Impedance	5
II-3. Frequency	6
II-4. Bandwidth.....	6
II-5. Gain	6
II-6. Polarization	7
II-6-A. Linear Polarization	8
II-6-B. Circular Polarization	8
II-6-C. Elliptical Polarization	8
III. Antenna categories	9
III-1. Dipole Wire Antenna	9
III-2. Helical Antenna	10
III-2-A. Applications	11
III-3. Parabolic Reflector Antenna	11
III-3-A. Types of Parabolic Antennas.....	12
III-3-B. Applications of Parabolic Reflector Antennas.....	12
III-4. Horn Antenna.....	13
III-4-A. Types of Horn Antennas.....	14
III-5. Log-Periodic Antenna.....	15

CONTENTS

III-5-A. Applications of Log-Periodic Antennas	15
III-6. Yagi Antenna	16
III-7. Microstrip Antenna	17
III-7-A. Characteristics.....	19
III-7-B. Advantages.....	19
III-7-C. Disadvantages	19
III-7-D. ANTENNA ARRAYS	20
III-7-D-1. Array Antenna Types:	21
➤ Broadside Antenna Array.....	21
➤ End-Fire Antenna Array.....	22
➤ Collinear Array.....	23
➤ Parasitic Array.....	23
III-7-F. Applications of Patch Antenna	24
III-8. Slot Antenna	25
III-8-A. Applications of Slot Antennas	25
IV. Applications in the S bands	26
V. Conclusion.....	27
Chapter II: Intercommunication between drones and GEO satellites	29
I. Introduction	29
II. Satellites and its applications	29
II-1. Satellites	29
II-2. Applications of Satellites.....	31
II-2-A. Weather forecasting.....	31
II-2-B. Navigation	31
II-2-C. Astronomy	31
II-2-D. Satellite phone	32
II-2-E. Satellite television.....	32
II-2-F. Military satellite	32
II-2-G. Satellite internet.....	33
II-2-H. Satellite radio.....	33
I. Drones and their applications	33
III-1. The drone.....	33

CONTENTS

III-2. Applications of the drones	34
III-2-A. Military Drone Technology	34
III-2-B. Delivery Drone Technology	34
III-2-C. Drone for Emergency	35
III-2-D. Drone for Agriculture	35
III-2-E. Drone for Outer Space	36
III-2-F. Drone for Wildlife and Historical Conservation.....	37
III-2-G. Drone in Medicine	37
III-2-H. Drone for 3D Modeling	38
III-2-I. Drone for Photography	38
III-2-J. Drone technology.....	39
II. GEO/Drone transmission chain	40
IV-1. GEO Satellite Communication Transmission Chain	40
IV-1-A. Uplink Transmission.....	40
IV-1-B. Downlink Transmission	41
IV-2. Drone Communication Transmission Chain	42
IV-2-A. Control and Data Uplink	42
IV-2-B. Onboard Systems.....	42
IV-2-C. Data Downlink.....	42
IV-3. Key Differences	43
III. DATASHEET ANTENNA	44
IV. Specifications for Drone/GEO intercommunication	46
V. Conclusion.....	47
Chapter III: Design and simulation antenna in S band	48
I. Introduction	48
II. CST studio software Tools	49
II-1. CST Studio	49
II-2. The CST software interfaces	49
III. Design and molding.....	51
IV. Result and discussion	53

CONTENTS

IV-1. One element antenna patch	53
IV-2. Array antenna patch.....	57
V. Conclusion.....	61
General Conclusion	61
References	A

ACRONYMS AND ABBREVIATIONS

B

Band Ku

Band Kurz-Unten

C

CST

Computer Simulation Technology

E

EIRP

Effective Radiated Power

F

FSL

Free Space Optical

G

GPS

Global Positioning System

H

HPBW

Half Power Beam Width

L

LP

Propagation loss

P

PIRE

Equivalent isotropic radiated power

PE

Emitted Power

R

RF

Radio Frequency

ROS

Rapport of Ondes Stationaries

S

SCAO

Altitude and Orbit Control System

SNR

Signal-to-Noise Ratio

T

TCR

Tracking Command And ranging

TTC

Telemetry, Tracking and Command

U

UHF

Ultra Haute Fréquence

UIT

Union Internationale des Télécommunications

ULB

Ultra Large Band

UART

Universal Asynchronous Receiver/Transmitter

ULB

Ultra large band

Universal Asynchronous Receiver/Transmitter

LIST OF FIGURES

CHAPITRE I

Figure I. 1: Antenna Directivity [I-1].	5
Figure I. 2: Frequency characteristics of the patch antennas [I-2].	6
Figure I. 3: Bandwidth of antenna [I-3].	6
Figure I. 4: Antenna polarization [I-5].	8
Figure I. 5: Circular Polarization [I-6].	8
Figure I. 6: Elliptical Polarization [I-7].	9
Figure I. 7: Dipole Wire Antenna [I-8].	10
Figure I. 8: Helical Antenna [I-9].	11
Figure I. 9: Schematic of Parabolic Antenna [I-10].	12
Figure I. 10: Different Types of Horn Antenna [I-11].	14
Figure I. 11: Log-Periodic Antenna [I-12].	15
Figure I. 12: Yagi Antenna [I-13].	17
Figure I. 13: Microstrip Antenna [I-14].	18
Figure I. 14: Power divisor microstrip patch antenna array [I-15].	21
Figure I. 15: Broadside Antenna Array [I-16].	21
Figure I. 16: End Fire Type Diagram [I-16].	22
Figure I. 17: Collinear Antenna Array [I-16].	23
Figure I. 18: Parasitic Type [I-16].	24

CHAPITRE II

Figure II. 1: Military telecommunications satellite [II- 1]	31
Figure II. 2: The drone [II- 2].	34
Figure II. 3: Military Drone Technology [II-3].	34
Figure II. 4: Delivery Drone Technology [II-4].	35
Figure II. 5: Drone for Emergency Public Rescue [II- 5]	35
Figure II. 6: Drone for Agriculture [II-6].	36
Figure II. 7: Drone for Outer Space [II-7].	36
Figure II. 8: Drone for Wildlife and Historical Conservation [II-8].	37
Figure II. 9: Drone in Medicine [II-9].	38
Figure II. 10: Drone for 3D Modeling [II-10].	38
Figure II. 11: Drone technology [II-11].	40
Figure II. 12: Satellite uplink transmission [II-12].	41
Figure II. 13: Downlink Transmission System Model [II-13].	41
Figure II. 14: Uplink and Downlink transmission [II-14].	42
Figure II. 15: Architecture of UAV system [II-15].	44
Figure II. 16: Architecture of UAV system [II-16].	45

CHAPITRE III

Figure III. 1: Interface du CST [III-1].	50
Figure III. 2: Structure of the Single-element patch antenna.	51
Figure III. 3: Structure of the 1*2 element patch antenna array.	51
Figure III. 4: Structure of the 2*2 element patch antenna array a) patch side, b) grand side.	52
Figure III. 5: Structure of the 2*4 element patch antenna array	53
Figure III. 6: S-Parameters of single patch antenna.	54
Figure III. 7: Efficiencies of single patch antenna.	54
Figure III. 8: Gain of single patch antenna.	55
Figure III. 9: Radiation pattern of single patch antenna.	56
Figure III. 10: S-Parameters of Array antenna patch.	57
Figure III. 11: Efficiencies of Array antenna patch.	58
Figure III. 12: Gain of Array antenna patch.	59
Figure III. 13: Radiation pattern of Array antenna patch	61



LIST OF TABLES

CHAPITRE I

CHAPITRE II

Table II- 1: Antenna patch parameters. 46

CHAPITRE III

GENERAL INTRODUCTION

GENERAL INTRODUCTION

The integration of drones with satellite networks has brought forth a myriad of possibilities across various sectors, from surveillance to disaster response. A pivotal aspect of these operations lies in establishing robust communication links between drones and geostationary (Geo) satellites. This work explores the development and implementation of a Tracking, Telemetry, and Control (TTC) antenna operating within the S-band frequency range, specifically engineered for facilitating communication between drones and Geo satellites.

Operating within the S-band frequency spectrum, typically spanning from 2 to 4 GHz, offers a favorable balance between communication range and atmospheric attenuation, making it an ideal choice for establishing long-range communication links. Key design considerations for the TTC antenna include optimizing gain to compensate for the relatively low transmit power of drones, enabling beam-steering capabilities to accurately track the position of Geo satellites, and ensuring a lightweight and compact form factor to align with the payload constraints of unmanned aerial vehicles (UAVs).

This thesis delves into the intricate design processes, electromagnetic simulations, and practical challenges encountered during the development of an efficient TTC antenna tailored for drone-to-Geo satellite communication. Insights garnered from this study aim to advance aerial communication systems and broaden their applicability across diverse domains.

This thesis is divided into three chapters. The first chapter includes A General information about antennas. We start by giving a characteristic of the antennas such as the radiation pattern, gain and directivity, polarization, reflection coefficient and bandwidth. And Antennas categories, and the geometry of the antennas . [1]

The second chapter was dedicated to Intercommunication between drones and GEO satellites, satellites and its applications, drones and their applications, geo/drone transmission chain etc.

The third chapter is intended to model and simulate the antenna design printed by CST (CST Microwave Studio), and to conclude the results of the coefficient of reflection S11, The gain, etc.

Finally, we end this dissertation with a general conclusion.

Chapter I

***GENERAL INFORMATION ON
ANTENNAS***

CHAPTER I: GENERAL INFORMATION ON PATCH ANTENNAS

I. INTRODUCTION

Antennas are indispensable components in a wide array of communication and sensing systems, bridging the gap between electromagnetic waves and electrical signals. With diverse forms and sizes, antennas are meticulously crafted for specific applications, spanning terrestrial communication to extraterrestrial exploration. Grasping the underlying principles governing antennas is paramount for fine-tuning signal transmission and reception in the realm of modern wireless technology.

Recent literature accentuates the pivotal role of antennas in unlocking advanced communication capabilities. For instance, Smith et al. (2023) [2], delve into the intricacies of designing and optimizing antennas tailored for 5G networks, spotlighting the pivotal role of antenna performance in achieving stellar data rates and network resilience.

Moreover, antennas feature prominently in cutting-edge technologies such as the Internet of Things (IoT) and autonomous vehicles. Chen et al. (2022) [3], delve into the intricacies of designing compact and efficient antennas optimized for IoT devices, facilitating seamless connectivity within smart environments.

In coastal and harbor areas, where maritime communication stands as a linchpin, recent studies by Li et al. (2024) [4], and Wang et al. (2023) [5], shed light on the utilization of S-band antennas for maritime surveillance and navigation. These studies underscore the criticality of antenna design and deployment in safeguarding the efficacy and safety of maritime operations.

In essence, antennas serve as the backbone of communication systems, fostering connectivity and data exchange across myriad domains. Recent literature underscores ongoing research endeavors aimed at bolstering antenna performance and fostering novel applications across diverse fields. [6]

II. CHARACTERISTICS OF THE ANTENNAS

Six main factors which differentiate antennas are impedance, directivity, frequency, the bandwidth, Gain and polarization. When selecting an antenna for a particular application, these factors should be considered. In this section, these and other factors which influence antenna selection are discussed .[7]

II-1. Directivity

In the realm of electromagnetism, directivity stands as a crucial parameter for antennas or optical systems, quantifying the extent to which emitted radiation is focused in a specific direction. It represents the ratio of radiation intensity in a specified direction relative to the average radiation intensity across all directions. The directivity of an ideal isotropic radiator is consequently set at 1 or 0 decibels (dB).

An antenna's directivity exceeds its gain by a factor of efficiency known as radiation efficiency. This metric holds significance as many antennas and optical systems are engineered to emit electromagnetic waves in a singular direction or within a narrow angle. Following the principle of reciprocity, an antenna's directivity remains consistent whether transmitting or receiving.

The actual directivity of an antenna can vary significantly, ranging from 1.76 dB for a compact dipole to as high as 50 dB for a sizable dish antenna. [8]

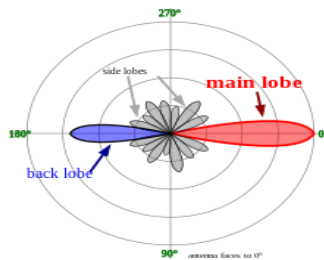

Figure I. 1: Antenna Directivity. [I-1]

II-2. Impedance

Both antennas and transmission lines have characteristic impedance. The term transmission line is defined in Sec. 4.3 as a long pair of conductors. If the length of the conductors is long compared to the wavelength of signal transmitted, the voltage and current may vary along the length of the line, and energy may be stored in the line. For this reason, transmission lines are described by characteristic impedance in ohms. The characteristic impedance gives the ratio of voltage to current along the line, and it provides information on the ability of the transmission line to store energy in the electric and magnetic field. Typical values for the impedance of transmission lines used for communications are 50 or 77 Ω . Similarly, each antenna has its own characteristic impedance, measured in ohms, which represents the ratio of voltage to current in the antenna. [9]

II-3. Frequency

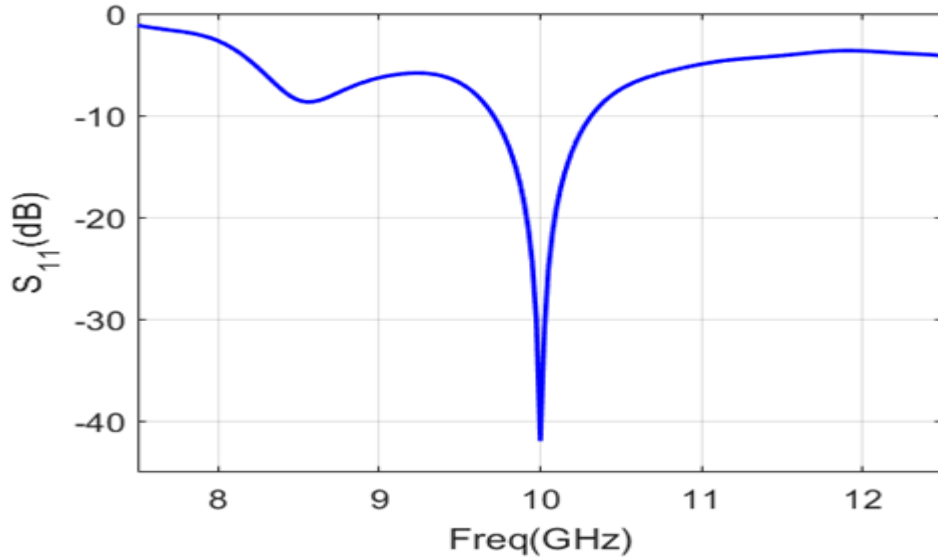

Figure I. 2: Frequency characteristics of the patch antennas .[I-2]

II-4. Bandwidth

The bandwidth of antenna is defined as the range of frequencies over which the characteristics of the antenna are maintained to the specified value. This is because, the requirements for the characteristics of an antenna like the gain, impedance, standing wave ratio etc. may change during operation .[11]

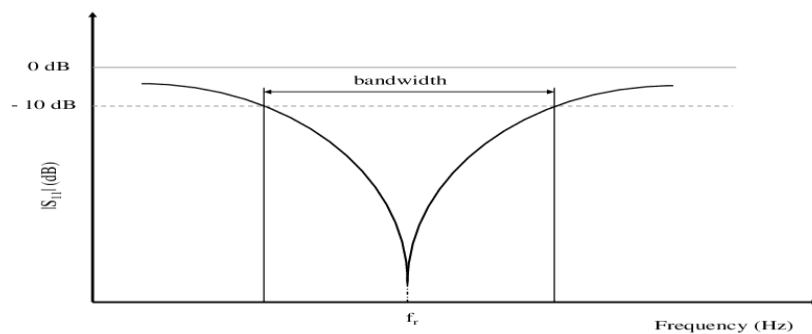

Figure I. 3: Bandwidth of antenna. [I-3]

II-5. Gain

Gain is a parameter which measures the degree of directivity of the antenna’s radiation pattern. A high gain antenna will radiate most of its power in a particular direction, while a low-gain antenna will radiate over a wide angle.

$$G_{dBi} = 10 \log \frac{I}{I_{iso}} \quad (I - 1)$$

A second unit used to measure gain is the ratio of the power radiated by the antenna to the power radiated by a half-wave dipole antenna, these units are called “decibels-dipole” (*dBd*)

$$G_{dBd} = 10 \log \frac{I}{I_{dipole}} \quad (I - 2)$$

Since the gain of a half-wave dipole is 2.15 *dB* and the logarithm of a product is additive, the gain in *dB* is just 2.15 decibels greater than the gain in *dB*

$$G_{dBi} = G_{dBd} + 2.15 \quad (I - 3)$$

High-gain antennas have the advantage of longer range and better signal quality, but must be aimed carefully at the other antenna.

An example of a high-gain antenna is a parabolic dish such as a satellite television antenna. Low-gain antennas have shorter range, but the orientation of the antenna is relatively unimportant. An example of a low-gain antenna is the whip antenna found on portable radios and cordless phones. Antenna gain should not be confused with amplifier gain, a separate parameter measuring the increase in signal power due to an amplifying device placed at the front-end of the system, such as a low-noise amplifier. [12]

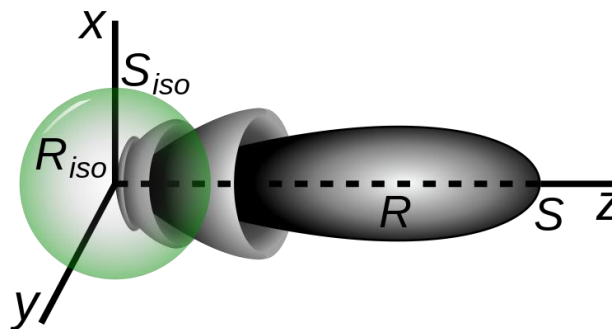

Figure I. 4: Antenna gain .[I-4]

II-6. Polarization

Following are the three types of polarization depending on how the electric field is oriented [13]:

II-6-A. Linear Polarization

In linear polarization, the electric field of light is limited to a single plane along the direction of propagation.

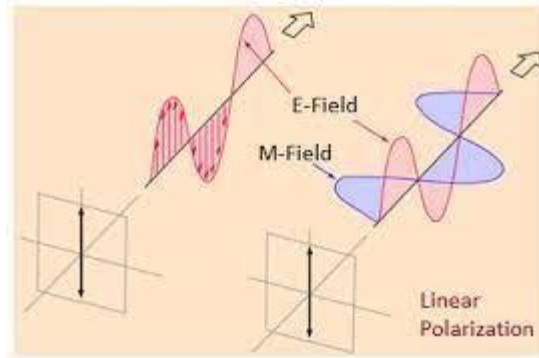

Figure I. 4: Antenna polarization .[I-5]

II-6-B. Circular Polarization

There are two linear components in the electric field of light that are perpendicular to each other such that their amplitudes are equal, but the phase difference is $\pi/2$. The propagation of the occurring electric field will be in a circular motion. [14]

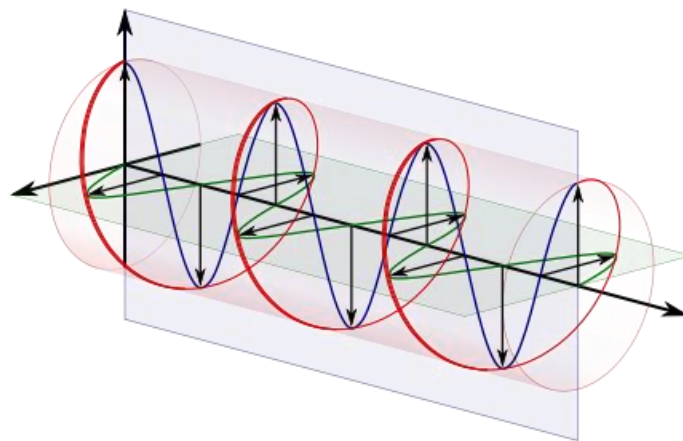

Figure I. 5: Circular Polarization .[I-6]

II-6-C. Elliptical Polarization

The electric field of light follows an elliptical propagation. The amplitude and phase difference between the two linear components are not equal. [15]

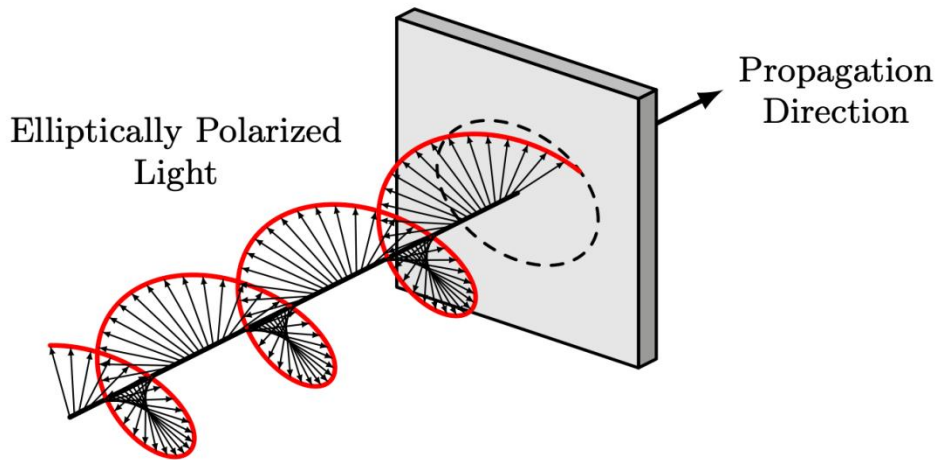

Figure I. 6: Elliptical Polarization. [I-7]

III. ANTENNA CATEGORIES

Antennas come in various categories, each designed for specific purposes. Here are some common categories:

III-1. Dipole Wire Antenna

A dipole antenna is a type of RF antenna consisting of two conductive elements, such as wires or rods, with a length approximately equal to half the highest wavelength in free space at the operating frequency. These elements are separated by an insulator at the antenna's center, forming what is known as the antenna section. Below is a diagram illustrating a dipole antenna: [Insert dipole diagram here]. When an RF voltage source is applied to the center of the antenna, voltage and current propagate along the two conductive elements, generating an electromagnetic or radio signal that is radiated from the antenna. In the middle of the antenna, voltage is at its minimum while current is at its maximum. Conversely, at the two ends of the dipole antenna, voltage is at its maximum while current is at its minimum.

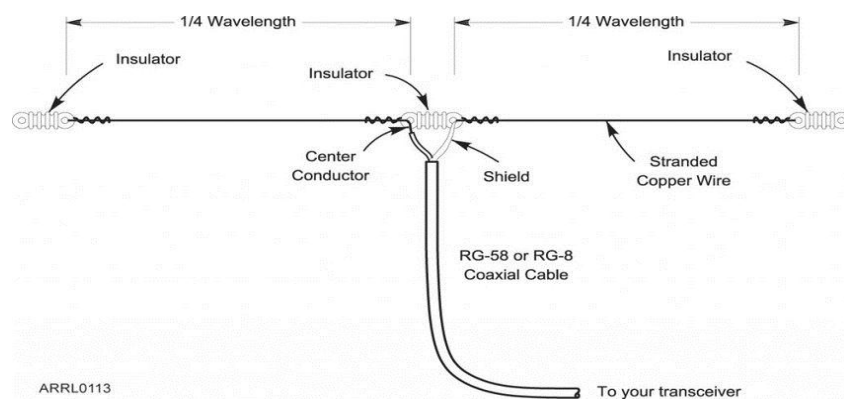

Figure I. 7: Dipole Wire Antenna. [I-8]

III-2. Helical Antenna

Helical antenna or helix antenna is the antenna in which the conducting wire is wound in helical shape and connected to the ground plate with a feeder line. It is the simplest antenna, which provides circularly polarized waves. It is used in extra-terrestrial communications in which satellite relays etc., are involved.

The above image shows a helical antenna system, which is used for satellite communications. These antennas require wider outdoor space.

It consists of a helix of thick copper wire or tubing wound in the shape of a screw thread used as an antenna in conjunction with a flat metal plate called a ground plate. One end of the helix is connected to the center conductor of the cable and the outer conductor is connected to the ground plate.

The image of a helix antenna detailing the antenna parts is shown above.

The radiation of helical antenna depends on the diameter of helix, the turn spacing and the pitch angle.

Pitch angle is the angle between a line tangent to the helix wire and plane normal to the helix axis.



Figure I. 8: Helical Antenna. [I-9]

III-2-A. Applications

The following are the applications of Helical antenna

- A single helical antenna or its array is used to transmit and receive VHF signals
- Frequently used for satellite and space probe communications
- Used for telemetry links with ballistic missiles and satellites at Earth stations
- Used to establish communications between the moon and the Earth
- Applications in radio astronomy

III-3. Parabolic Reflector Antenna

A parabolic reflector antenna, often simply referred to as a ‘parabolic antenna’, is a type of high-gain antenna that uses a parabolic reflector, a curved surface with the cross-sectional shape of a parabola, to direct the radio waves. The most common form is shaped like a dish and is popularly called a dish antenna or parabolic dish. The main advantage of a parabolic antenna is its high directivity.

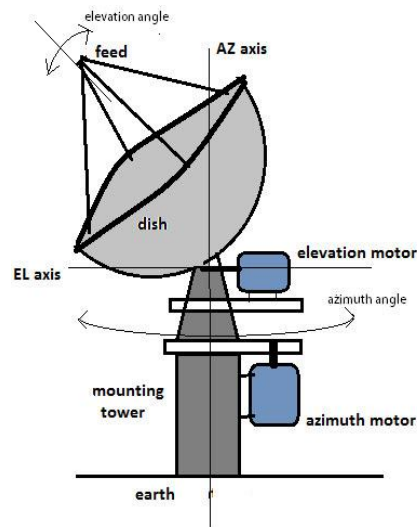

Figure I. 9: Schematic of Parabolic Antenna. [I-10]

III-3-A. Types of Parabolic Antennas

1. Front-fed or axial parabolic antenna:

In this design, the feed antenna is located in front of the parabola at its focus. It's the most common form of parabolic antenna and offers high gain and directivity.

2. Offset parabolic antenna:

In an offset design, the feed antenna is off to the side. This arrangement prevents the feed antenna and its support structure from blocking the beam of radio waves, increasing efficiency.

3. Cassegrain antenna:

This design features a secondary reflector at the focus of the main parabolic reflector. The secondary reflector redirects the radio waves into a line perpendicular to the axis of the main reflector, where the feed antenna is located.

The choice of parabolic antenna design largely depends on the specific application, considering factors such as required gain, beam width, and polarization.

III-3-B. Applications of Parabolic Reflector Antennas

Parabolic reflector antennas have a broad range of applications, owing to their high gain and directivity. These features make them an ideal choice for use in various areas of telecommunications and broadcasting.

- **Satellite Communication:**

One of the most common uses of parabolic antennas is in satellite communication, for both uplink and downlink communications. The high gain and directivity of these antennas allow them to communicate effectively with satellites in space.

- **Radio and Television Broadcasting:**

Parabolic antennas are frequently used in the broadcast industry, particularly for transmitting signals over long distances.

- **Radar Systems:**

The high directivity of parabolic antennas makes them ideal for use in radar systems, where the direction of the signal is of great importance.

- **Wireless Data Links:**

Parabolic antennas are also used in point-to-point wireless data links, including Wi-Fi and cellular networks.

III-4. Horn Antenna

A horn antenna is a microwave antenna that consists of a waveguide whose end is flared out in the form of a horn. The flaring increases the antenna's directivity and gain, making it an effective radiating element. Horn antennas are particularly useful in the frequency range of 1 GHz to 100 GHz, offering a high degree of directivity and low standing wave ratio (SWR). They are employed in a wide range of applications, including satellite communications, radio astronomy, radar systems, and microwave link systems.

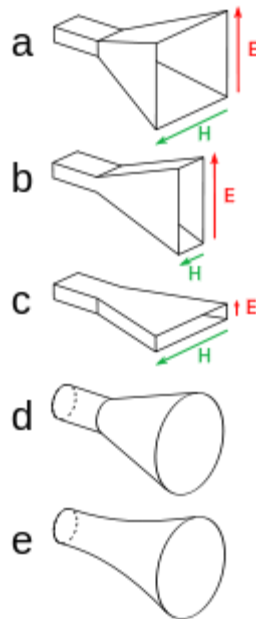

Figure I. 10: Different Types of Horn Antenna .[I-11]

III-4-A. Types of Horn Antennas

There are several types of horn antennas, each with their own advantages and characteristics. Some of the most common types include:

- **Pyramidal Horn Antenna:**

This type of horn antenna features a rectangular waveguide that flares out into a pyramidal shape. Pyramidal horn antennas provide high directivity and gain, making them suitable for various applications, including radar and communication systems.

- **Conical Horn Antenna:**

The conical horn antenna consists of a circular waveguide that expands into a conical shape. These antennas offer a more symmetrical radiation pattern and are commonly used in satellite communication systems and radio astronomy.

- **Corrugated Horn Antenna:**

This design incorporates corrugations or grooves along the inner surface of the horn, improving the antenna's impedance matching and radiation pattern. Corrugated horn antennas are often used in high-frequency applications, such as radio astronomy and satellite communications.

- **Exponential Horn Antenna:**

Exponential horn antennas, also known as scalar feed horns, have a flare rate that increases exponentially. This results in a smooth radiation pattern with low sidelobe levels, making them ideal for radio astronomy and other applications requiring minimal interference

III-5. Log-Periodic Antenna

The log-periodic antenna is a unique and versatile antenna design that has found widespread use in various applications, including television reception, shortwave broadcasting, and even scientific research. Invented by Raymond H. DuHamel and Dwight E. Isbell in 1957, this antenna offers a range of desirable characteristics, such as wideband frequency coverage, consistent impedance, and manageable directivity. This article aims to introduce the design and operation of log-periodic antennas and explore their key features and common applications.



Figure I. 11: Log-Periodic Antenna .[I-12]

III-5-A. Applications of Log-Periodic Antennas

Thanks to their versatile characteristics, log-periodic antennas are used in a wide variety of applications:

- **Television Reception:**

Log-periodic dipole arrays are commonly used as TV antennas due to their broadband performance, which allows them to receive multiple channels simultaneously.

- **Shortwave Broadcasting:**

The wide frequency range and directional radiation pattern of log-periodic antennas make them well-suited for shortwave broadcasting, enabling reliable communication over large distances.

- **Amateur Radio:**

Radio amateurs often employ log-periodic antennas for their ability to operate efficiently across multiple frequency bands, allowing for greater flexibility in communication modes and band choices.

- **Radar and Microwave Applications:**

Log-periodic slot arrays are frequently used in radar and microwave applications due to their planar structure, which enables easy integration with associated electronic components.

- **Scientific Research:**

Researchers in fields such as radio astronomy, ionospheric studies, and electromagnetic compatibility testing use log-periodic antennas to capture and analyze wideband signals across a broad range of frequencies.

III-6. Yagi Antenna

A Yagi antenna or a Yagi-Uda antenna, is a directional antenna that radiates signals in one main direction. It consists of a long transmission line with a single driven element consisting of two rods connected on either side of the transmission line. It also consists of a single reflector on one side of the transmission line and a number of parasitic elements which act as directors. The driven element of a Yagi is equivalent of a center-fed, half-wave dipole antenna. Parallel to the driven element are straight rods or wires called reflectors and directors. A reflector is placed behind the driven element and is slightly longer than driven element; a director is placed in front of the driven element and is slightly shorter than driven element. A typical Yagi antenna has one reflector and one or more directors.

The Yagi-Uda antenna was optimized by radio amateur Rainer Bertelsmeier (callsign DJ9BV) under the principle of the "long Yagi DJ9BV". At an equivalent boom length, it has fewer elements than a typical Yagi-Uda antenna. The DJ9BV antenna has improved performance, particularly on gain.

This is a variation of the dipole, using multiples wires (with one “reflector” and one or more “directors” (acting as a lens).

- Low bandwidth
- Moderate directivity

- Commonly used as a UHF TV antenna



Figure I. 12: Yagi Antenna. [I-13]

III-7. Microstrip Antenna

The microstrip antenna is a relatively modern invention. It was invented to allow convenient integration of an antenna and other driving circuitry of a communication system on a common printed-circuit board or a semiconductor chip (Carver and Mink, 1981; Pozar, 1992). Besides other resulting advantages, the integrated-circuit technology for the antenna fabrication allowed high dimensional accuracy, which was otherwise difficult to achieve in traditional fabrication methods.

The geometry of a microstrip antenna consists of a dielectric substrate of certain thickness d , having a complete metallization on one of its surfaces and of a metal “patch” on the other side. The substrate is usually thin ($d \ll \lambda$). The metal patch on the front surface can have various shapes, although a rectangular shape, is commonly used. The antenna may be excited using various methods (Pozar, 1992; Pozar and Schawbert, 1995) [17]. One common approach is to feed from a microstrip line, connecting the microstrip antenna at the center of one of its edges. The microstrip line may be connected to a feeding circuitry or directly fed by connecting a signal source across the microstrip line and the ground plane.

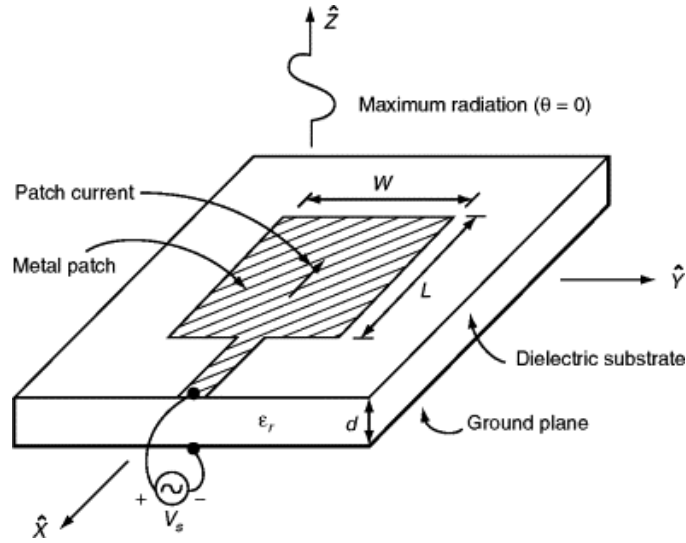

Figure I. 13: Microstrip Antenna. [I-14]

$$\epsilon_{\text{eff}} = \frac{\epsilon_R + 1}{2} + \frac{(\epsilon_R - 1)}{2} \left[\frac{1}{\sqrt{1 + 12 \left(\frac{h}{w} \right)}} \right] \quad (\text{I-4})$$

$$w = \frac{c}{2 * f_0 * \sqrt{\frac{\epsilon_R + 1}{2}}} \quad (\text{I-5})$$

$$L = \frac{c}{2 * \sqrt{\epsilon_{\text{eff}}} * f_0} - 0.824h \left(\frac{(\epsilon_{\text{eff}} + 0.3) \left(\frac{w}{h} + 0.264 \right)}{(\epsilon_{\text{eff}} - 0.258) \left(\frac{w}{h} + 0.8 \right)} \right) \quad (\text{I-6})$$

When higher order mode is desired, the width, length and frequency must meet the following equation:

$$f_{ijk} = \frac{c}{2\sqrt{\epsilon_{\text{eff}}}} \left[\left(\frac{i}{L^*} \right)^2 + \left(\frac{j}{W} \right)^2 + \left(\frac{k}{h} \right)^2 \right]^{1/2} \quad (\text{I-7})$$

Where i, j, k are integers

Note that the term L^* refers to L above, plus the second term to the right:

$$L^* = L + 0.824h \left(\frac{(\epsilon_{\text{eff}} + 0.3) \left(\frac{w}{h} + 0.264 \right)}{(\epsilon_{\text{eff}} - 0.258) \left(\frac{w}{h} + 0.8 \right)} \right) = \frac{c}{2f_0\sqrt{\epsilon_{\text{eff}}}} \quad (\text{I-8})$$

The main set of design equations for L and W assumes that we operate in mode (i, j, k) $(1, 0, 0)$.

The next highest order frequency involving L^* sets a limit for the patch antenna due to its edge excitation. By replacing the above equation of L with this equation you obtain a more complex equation dependent on frequency and W taking h as a parameter. This equation can then be solved by hand, by plotting a graph of the intersections, or by using a random search application like differential evolution .[16]

III-7-A. Characteristics

- The patch of the antenna must be a very thin conductive region, $t \ll \lambda_0$ (λ_0 free space wavelength).
- The ground plane must have comparatively very large dimensions than the patch.
- Photo-etching is done to fabricate the radiating element and feed lines on the substrate.
- A thick dielectric substrate with dielectric constant within the range of 2.2 to 12 provides good antenna performance.
- Arrays of microstrip elements in the antenna configuration provide greater directivity.
- Microstrip antennas provide high beamwidth.
- A very high-quality factor is offered by a patch antenna. A large Q results in a narrow bandwidth and low efficiency. However, this can be compensated by increasing the thickness of the substrate. However, the increase in thickness beyond a certain limit will cause an unwanted loss of power.

III-7-B. Advantages

- The antenna is of small size and less bulky.
- It offers an easy fabrication process.
- Due to less volume and small size, there is an easy installation.
- It provides easy integration with other devices.
- It can perform dual and triple frequency operations.
- The arrays of the antenna can be easily constructed.
- It offers a high degree of robustness over rigid surfaces.

III-7-C. Disadvantages

- The antenna efficiency is low.

- These antennas show highly sensitive behavior towards environmental factors.
- These exhibit low power handling ability, low gain, and narrow bandwidth.
- These are more prone to spurious feed radiation.
- There are more dielectric and conductor losses in microstrip antennas.

III-7-D. ANTENNA ARRAYS

Antennas with a given radiation pattern may be arranged in a pattern line, circle, plane, etc.).

To yield a different radiation pattern. Antenna array configuration of multiple antennas (Elements) arranged to achieve a given radiation pattern. Simple antennas can be combined to achieve desired directional effects. Individual antennas are called elements and the combination is an array.

An array of antennas may be used in a variety of ways to improve the performance of a communications system. Perhaps most important is its capability to cancel co channel interferences. An array works on the premise that the desired signal and unwanted co channel interferences arrive from different directions. The beam pattern of the array is adjusted to suit the requirements by combining signals from different antennas with appropriate weighting.

An array of antennas mounted on vehicles, ships, aircraft, satellites, and base stations is expected to play an important role in fulfilling the increased demand of channel requirement for these services

Patch antennas come in various shapes and sizes and consist of a patch of metal directly above a ground plane. Figure I-14 shows an example of a patch antenna. The main disadvantage of these antennas is their relatively large size compared to other types of antennas. For example, some patch antennas are approximately half a wavelength on each side. The polarization can be either circular or linear depending on the design of the patch.

In a patch antenna, most of the propagation is above the ground plane and can have high directional gain.

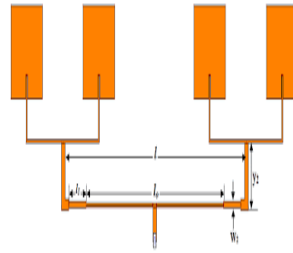

Figure I. 14: Power divisor microstrip patch antenna array. [I-15]

III-7-D-1. Array Antenna Types:

Array antennas are classified into four types broadside, end-fire, collinear & parasitic antenna array where each type is discussed below .[17]

➤ **Broadside Antenna Array**

The broadside antenna array arrangement is shown below where various identical elements are parallelly arranged along the antenna axe line. In this type of arrangement, the elements are arranged horizontally arranged at an equivalent distance to each other & every element is fed by a current of similar phase & magnitude.

Whenever the elements in this arrangement are energized then maximum radiation will be emitted from the broadside which means the normal direction to the array axis whereas some amount of radiation will be emitted from the other directions. So, it provides a bidirectional radiation pattern because it radiates within both directions along the broadside. Therefore, in this arrangement, the direction of radiation principle is common to the array axis & the plane of element position. The radiation pattern of the broadside antenna array is shown below.

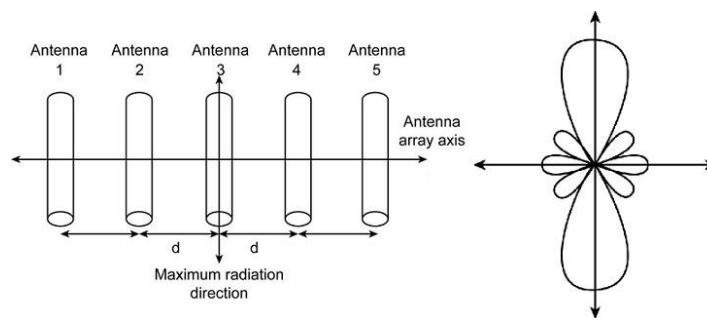

Figure I. 15: Broadside Antenna Array .[I-16]

The radiation pattern of the broadside antenna array is vertical because the element's alignment is horizontal.

If we want to change the radiation pattern from bidirectional to unidirectional then a similar array needs to arrange at $\lambda/4$ distance behind this antenna array & exciting the replica array through a current having a 90° phase lead. Usually, the number of elements within this arrangement depends on available space with the need of cost & beam width whereas the array length is taken in between 2λ to 10λ . Generally, these antenna arrays are used in overseas broadcasting systems.

➤ *End-Fire Antenna Array*

An end-fire antenna array arrangement is the same as elements in the broadside arrangement however the main difference between these two configurations is the way of excitation. In this arrangement, the elements are generally fed out of phase with 180° , whereas in broadside arrangement each element is fed with the current of a similar phase. In this arrangement, the maximum radiation is attained along the array axis.

Thus, in order to get a unidirectional radiation pattern, this complete identical element arrangement is simply energized with equivalent amplitude current, however, the phase changes continuously along the line. So, it can be stated that an end-fire array generates a unidirectional radiation pattern by the highest radiation occurring through the axis of the antenna array.

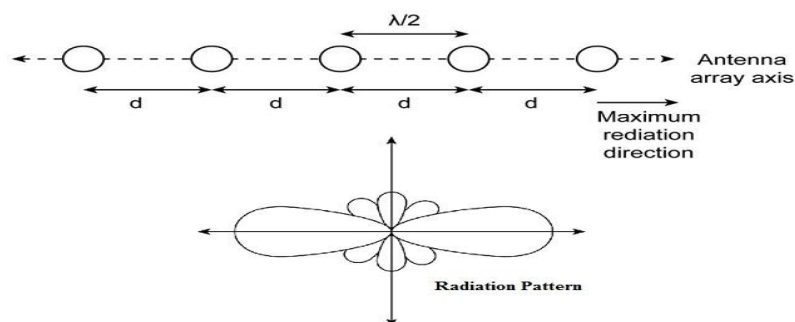

Figure I. 16: End Fire Type Diagram.[I-16]

In the above radiation pattern diagram, the main distance between the elements within this arrangement is normally understood as $\lambda/4$ (or) $3\lambda/4$. These arrays are most frequently used in point-to-point communication & are appropriate for high, medium, and low-frequency ranges.

➤ *Collinear Array*

In a collinear array, antenna elements are simply arranged in a single line from one end to the other which means one after the other. This arrangement can be either horizontal or vertical orientation. The collinear array with a horizontal arrangement is shown below.

To all the antenna elements, the excitation is provided by currents of the same phase & magnitude to all the elements. Similar to a broadside array, this also provides radiation in the normal direction to the antenna array axis. Thus, the radiation pattern of the collinear array is somewhat related to the broadside antenna array.

This arrangement simply offers the highest gain whenever the elements are spaced at 0.3 to 0.5λ distance but this can cause constructional as well as feeding issues within the antenna array. So, the elements are arranged closer to each other.

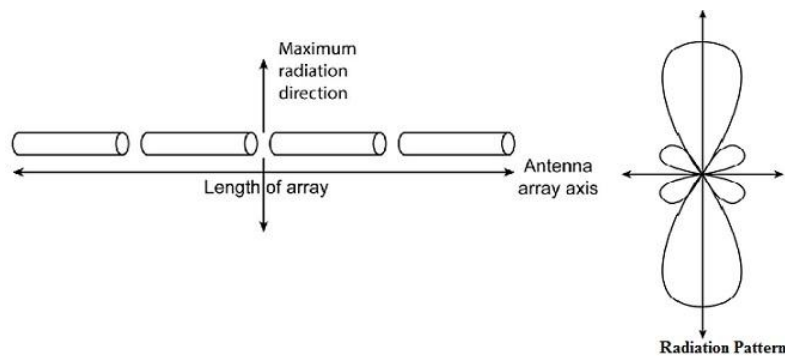

Figure I. 17: Collinear Antenna Array .[I-16]

The collinear array radiation pattern is shown above. It is to be noted here that with an increase in the length of the array the directivity also increases. Generally, two elements collinear array is generally used because it supports multi-band operation but sometimes, some applications utilize a combination of broadside, end-fire & collinear arrays because this enhances the directivity & gain to a very high range.

➤ *Parasitic Array*

The multi-element arrays like parasitic antenna elements are arranged parasitically which provides maximum directional gain without feeding every array element. This kind of arrangement simply helps in dealing with the feed line problem by not providing direct excitation to every antenna array element.

The parasitic antenna arrangement is shown below. The elements which are not fed directly are known as parasitic elements & they simply draw their power from the emitted radiation by the driven element that is present nearby. As a result, parasitic elements are activated by electromagnetic coupling since the driving element is nearby.

The antenna array's parasitic elements are not directly excited but they rely on the excitation delivered toward the driving element. So, the induced current within the parasitic element caused by the driven element is determined by the distance between these two elements & their tuning.

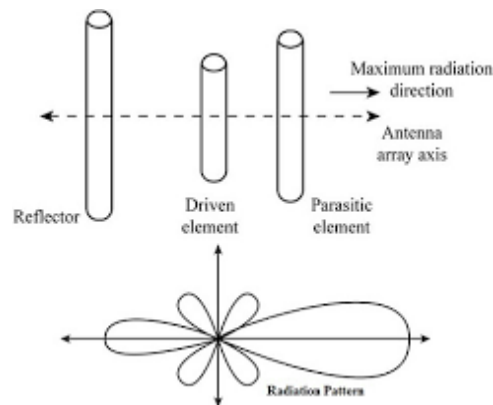

Figure I. 18: Parasitic Type. [I-16]

Thus, a unidirectional radiation pattern is produced with a ' $\lambda/4$ ' separation distance & 90° phase difference between the driving as well as parasitic elements. Thus, the radiation pattern of this array is simply created by a reflector arranged after the driving element, which includes back-reflected waves toward the forward wave. The range frequency for these types of antenna arrays ranges from 100 – 1000 MHz.

III-7-F. Applications of Patch Antenna

The low-profile structure of microstrip antennas offers its wide use in wireless communications. This is the reason these antennas show compatibility towards handheld devices like pagers and mobile phones.

Due to the thin structure of these antennas, these are used as communication antennas on missiles.

Satellite communication and microwave applications also make use of microstrip antenna due to its small size.

GPS i.e., the Global Positioning System is one of the major advantages of microstrip antennas. As it offers ease in tracking vehicles and marines.

These antennas also find applications in phased array radars that can handle bandwidth tolerance up to some percentage.

III-8. Slot Antenna

The fundamental principle behind a slot antenna is that it functions as the dual of a dipole antenna. In a dipole antenna, current flows through two rods or wires, creating an electric field that radiates electromagnetic waves. In a slot antenna, the current flows around the edges of the slot or aperture, resulting in a magnetic field that radiates the electromagnetic waves.

The size and shape of the slot determine the operating frequency and radiation pattern of the antenna. Typically, the length of the slot is approximately half the wavelength of the desired operating frequency. This length is important because it ensures the antenna is resonant, allowing it to efficiently transmit and receive signals.

III-8-A. Applications of Slot Antennas

Slot antennas have found their way into a wide variety of applications, including:

- **Radar systems:**

Due to their directional radiation pattern and wideband performance, slot antennas are commonly used in radar systems for aircraft, ships, and ground-based installations.

- **Satellite communications:**

Slot antennas are often used in satellite communication systems, where their low-profile design and high efficiency are critical for minimizing size and weight constraints.

- **Wireless networking:**

Slot array antennas are commonly used in wireless networking equipment, such as Wi-Fi access points and base stations, to provide directional coverage and improved signal strength.

- **Broadcast television:**

Alford slot antennas are frequently used in broadcast television systems, where their impedance matching characteristics and wideband performance are essential for transmitting and receiving television signals. [18]

IV. APPLICATIONS IN THE S BANDS

- The S-band (2-4 GHz) frequency is predominantly used for satellite communication and radar. S-band is of key importance to the shipping, aviation and space industries. Providers of S-band networks include Inmarsat, which launched its S-band satellite in June 2017 .[19]
- Flexible applications the S-band (2-4 GHz) frequency is used for satellite communication and radar. It is used by the shipping, aviation and space industries for its efficiency as a conduit for supplying vital real-time data and for high resilience to rain fade and other Environmental interference. S-band is used for an extensive range of cross-industry Applications, including surface ship radar, weather radar, navigational assistance, vessel Identification and tracking, air traffic control, inflight Wi-Fi and spacecraft telemetry. Large Parabolic antenna systems are needed for the best communications performance, however, smaller, Omni-directional S-band antenna systems are also available for specific applications. Providers of S-band networks include Inmarsat, which launched its Inmarsat S EAN S-band Satellite in June 2017 where Cobham SATCOM supplies the earth station infrastructure .[20]
- S band offers good compromise between resolution and range. This makes them suitable for various radar applications such as weather radar, ATC (air traffic control) radar and surveillance radar. It is used for both military and civilian purposes.
- Some satellite communication systems use S-band for telemetry and tracking applications. It is used for uplink communication (Ground to Satellite) in some satellite TV broadcasting systems.
- S band frequencies are used in aviation communication and navigation systems which include radar altimeters and collision avoidance systems.
- S band radar is used for maritime surveillance, navigation and collision avoidance especially in coastal and harbour areas.
- S band is used for data collection and analysis in some scientific research applications such as radio astronomy and atmospheric studies.
- Some Earth observation and remote sensing satellites may employ S band frequencies to transmit data back to the Earth.
- Mobile satellite services such as Inmarsat use S band for communication with mobile terminals and devices.

- Multimedia applications in mobile TV & satellite radio
- Consumer electronic appliances e.g. microwave oven, Bluetooth headphones etc.
- Optical communications in 1460 to 1530 nm wavelength
- S band offers good balance between resolution and range in radar systems which make them versatile for various surveillance and detection applications.
- S band systems are known for their reliability and resistance to signal interference which makes them suitable for critical applications in aviation and maritime industries.
- S band radar provides more accurate data due to their relatively smaller wavelengths which is used for weather forecasting and air traffic control (ATC).
- Satellite communication systems operating in S band offer global coverage which ensures Connectivity in remote and other underserved areas .[21]

V. CONCLUSION

The highlights the crucial role of antennas in contemporary communication systems. Antennas serve as the interface between electronic devices and the electromagnetic spectrum, facilitating signal transmission and reception. They are indispensable components in a range of applications, such as wireless communication, radar systems, satellite communication, and radio astronomy.

Antennas are available in various designs that are customized for specific applications and operating frequencies. Each design has its own advantages depending on factors such as gain, bandwidth, and radiation pattern requirements.

Chapter II

Intercommunication between drones and GEO satellite

CHAPTER II: INTERCOMMUNICATION BETWEEN DRONES AND GEO SATELLITES

I. INTRODUCTION

The technology necessary to create drones has been around for a considerable amount of time. The technology was first employed by the military, but it has since made its way into the consumer market and can be put to use in a variety of contexts. From aerial photography to the monitoring of construction sites, drone technology possesses a number of appealing characteristics that make it particularly useful in a number of contexts and are also becoming increasingly affordable.

There is already a rising demand among the community of telecom operators to employ these unmanned flying aircraft for particular objectives such as site monitoring. One example of this type of application is site inspection. This chapter aims to detail how drone technology can be further extended to improve serviceability, particularly whenever a network failure occurs that may affect the service quality, if not completely disrupt the whole connectivity service. In particular, the chapter will focus on improving serviceability whenever a network failure occurs. [22]

Geostationary satellites have the unique property of remaining permanently fixed in exactly the same position in the sky as viewed from any fixed location on Earth, meaning that ground-based antennas do not need to track them but can remain fixed in one direction. Chapter II of our work is intended to present the general information about intercommunication between drones and GEO satellites, represents a paradigm shift in aerospace technology, fostering greater connectivity, resilience, and functionality in unmanned aerial systems. As advancements continue to unfold, this synergy will continue to redefine the possibilities and applications of aerial platforms in the modern era. [23]

II. SATELLITES AND ITS APPLICATIONS

II-1. Satellites

A satellite or artificial satellite is an object, typically a spacecraft, placed into orbit around a celestial body. Satellites have a variety of uses, including communication

relay, weather forecasting, navigation (GPS), broadcasting, scientific research, and Earth observation.

Additional military uses are reconnaissance, early warning, signals intelligence and, potentially, weapon delivery. Other satellites include the final rocket stages that place satellites in orbit and formerly useful satellites that later become defunct.

Except for passive satellites, most satellites have an electricity generation system for equipment on board, such as solar panels or radioisotope thermoelectric generators (RTGs). Most satellites also have a method of communication to ground stations, called transponders. Many satellites use a standardized bus to save cost and work, the most popular of which is a small CubeSats.

Similar satellites can work together as groups, forming constellations. Because of the high launch cost to space, satellites are designed to be as lightweight and robust as possible. Most communication satellites are radio relay stations in orbit and carry dozens of transponders, each with a bandwidth of tens of megahertz.

Satellites are placed from the surface to the orbit by launch vehicles, high enough to avoid orbital decay by the atmosphere. Satellites can then change or maintain the orbit by propulsion, usually by chemical or ion thrusters. As of 2018, about 90% of the satellites orbiting the Earth are in low Earth orbit or geostationary orbit; geostationary means the satellites stay still in the sky. Some imaging satellites chose a Sun-synchronous orbit because they can scan the entire globe with similar lighting. As the number of satellites and space debris around Earth increases, the threat of collision has become more severe. A small number of satellites orbit other bodies (such as the Moon, Mars, and the Sun) or many bodies at once (two for a halo orbit, three for a Lissajous orbit). Earth observation satellites gather information for reconnaissance, mapping, monitoring the weather, ocean, forest, etc.

Space telescopes take advantage of outer space's near perfect vacuum to observe objects with the entire electromagnetic spectrum. Because satellites can see a large portion of the Earth at once, communications satellites can relay information to remote places. The signal delay from satellites and their orbit's predictability are used in satellite navigation systems, such as GPS. Space probes are satellites designed for robotic space exploration outside of Earth, and space stations are in essence crewed satellites.

The first artificial satellite launched into the Earth's orbit was the Soviet Union's Sputnik 1, on October 4, 1957. As of December 31st 2022, there are 6,718

operational satellites in the Earth's orbit, of which 4,529 belong to the United States (3,996 commercial), 590 belong to China, 174 belong to Russia, and 1,425 belong to other nations. [24]



Figure II. 1: Military telecommunications satellite. [II-1]

II-2. Applications of Satellites

Artificial satellites are used in various applications. The various applications of artificial satellites include:

II-2-A. Weather forecasting

Weather forecasting is the prediction of the future of weather. The satellites that are used to predict the future of weather are called weather satellites. Weather satellites continuously monitor the climate and weather conditions of earth. They use sensors called radiometers for measuring the heat energy released from the earth surface. Weather satellites also predict the most dangerous storms such as hurricanes.

II-2-B. Navigation

Generally, navigation refers to determining the geographical location of an object. The satellites that are used to determine the geographic location of aircrafts, ships, cars, trains, or any other object are called navigation satellites. GPS (Global Positioning System) is an example of navigation system. It allows the user to determine their exact location at anywhere in the world.

II-2-C. Astronomy

Astronomy is the study of celestial objects such as stars, planets, galaxies, natural satellites, comets, etc. The satellites that are used to study or observe the distant stars, galaxies, planets, are called astronomical satellites.

They are mainly used to find the new stars, planets, and galaxies. Hubble space telescope is an example of astronomical satellite. It captures the high-resolution images of the distant stars, galaxies, planets etc.

II-2-D. Satellite phone

Satellite phone is a type of mobile phone that uses satellites instead of cell towers for transmitting the signal or information over long distances.

Mobile phones that use cell towers will work only within the coverage area of a cell tower. If we go beyond the coverage area of a cell tower or if we reach the remote areas, it becomes difficult to make a voice call or send text messages with the mobile phones. Unlike the mobile mobiles, satellite phones have global coverage. Satellites phones uses geostationary satellites and low earth orbit (LEO) satellites for transmitting the information.

When a person makes a call from the satellite phone, the signal is sent to the satellite. The satellite will receive that signal, processes it, and redirects the signal back to the earth via a gateway. The gateway then sends the signal or call to the destination by using the regular cellular and landline networks. The usage of satellite phones is illegal in some countries like Cuba, North Korea, Burma, India, and Russia

II-2-E. Satellite television

Satellite television or satellite TV is a wireless system that uses communication satellites to deliver the television programs or television signals to the users or viewers.

TV or television mostly uses geostationary satellites because they look stationary from the earth. Hence, the signal is easily transmitted. When the television signal is sent to the satellite, it receives the signal, amplifies it, and retransmits it back to the earth. The first satellite television signal was sent from Europe to North America by using the Telstar satellite.

II-2-F. Military satellite

Military satellite is an artificial satellite used by the army for various purposes such as spying on enemy countries, military communication, and navigation.

Military satellites obtain the secret information from the enemy countries. These satellites also detect the missiles launched by the other countries in the space.

Military satellites are used by armed forces to communicate with each other. These satellites also used to determine the exact location of an object.

II-2-G. Satellite internet

Satellite internet is a wireless system that uses satellites to deliver the internet signals to users. High-speed internet is the main advantage of satellite internet. Satellite internet does not use cable systems, but instead it uses satellites to transmit the information or signal.

II-2-H. Satellite radio

Satellite radio is a wireless transmission service that uses orbiting satellites to deliver the information or radio signals to the consumers. It is primarily used in the cars. When the ground station transmit signal to the satellite that is revolving around the earth, the satellite receives the signal, amplifies it, and redirects the signal back to the earth (radio receivers in the cars) .[25]

I. DRONES AND THEIR APPLICATIONS

III-1. The drone

An unmanned aerial vehicle (UAV), commonly known as a drone is an aircraft without any human pilot, crew, or passengers on board. UAVs were originally developed through the twentieth century for military missions too "dull, dirty or dangerous" for humans, and by the twenty-first, they had become essential assets to most militaries. As control technologies improved and costs fell, their use expanded to many non-military applications.

These include aerial photography, precision agriculture, forest fire monitoring, river monitoring, environmental monitoring, policing and surveillance, infrastructure inspections, smuggling, product deliveries, entertainment, and drone racing. [26]



Figure II. 2: The drone. [II- 2]

III-2. Applications of the drones

III-2-A. Military Drone Technology

The military is probably the oldest, most well-known, and most contentious application of drones. In the early 1940s, the British and American forces began utilizing extremely crude kinds of drones to spy on the Axis powers. Drones today are far more advanced than UAVs of the past, including thermal imaging, laser range finders, and even airstrike instruments. The MQ-9 Reaper is a well-known military drone. The aircraft is 36 feet long, can travel 50,000 feet in the air undetected, and is outfitted with a variety of missiles and intelligence gathering systems.



Figure II. 3: Military Drone Technology .[II-3]

III-2-B. Delivery Drone Technology

Delivery drones are typically unmanned aerial vehicles (UAVs) that bring meals, packages, or commodities to your front door. These flying vehicles are known as “last mile” delivery drones because they make deliveries from nearby retailers or warehouses. Instead of

depending on delivery drivers with inefficient trucks, retailers and grocery chains throughout the country are turning to drones as a more effective delivery alternative. These drones can deliver 55 pounds of items to your front door without requiring you to leave the house. Amazon, Walmart, Google, FedEx, UPS, and many other major corporations are all testing various types of delivery drones.



Figure II. 4: Delivery Drone Technology .[II-4]

III-2-C. Drone for Emergency

Due to the scale or severity of the disaster, it is not always safe to send humans into a rescue situation. This is where drones come into play. In the event of a capsized boat or a drowning person, officials can deploy an Autonomous Underwater Vehicle (AUV) to assist in the rescue.



Figure II. 5: Drone for Emergency Public Rescue. [II- 5]

III-2-D. Drone for Agriculture

Drones have also shown to be advantageous to the agriculture business, providing farmers with a variety of options for optimizing their crops to maximize efficiency and

minimize physical strain. UAVs make field surveys, sowing across fields, tracking livestock, and predicting crop yields easier while saving agriculture workers important time.



Figure II. 6: Drone for Agriculture. [II-6]

III-2-E. Drone for Outer Space

NASA and the United States Air Force have been testing unmanned aircraft designed for space flight. The Air Force's ultra-secretive X-37B UAV looks like a small space shuttle. It has been quietly circling the Earth for the past two years, setting a record for the longest unmanned aircraft flight (781 days and counting). Although the Air Force has been ambiguous, it has stated that "the primary objectives of the X-37B are twofold: reusable spacecraft technologies for America's future in space and operating experiments that can be returned to, and examined on Earth." When it comes to the future of space exploration and innovation, it appears that drones have been prioritized.



Figure II. 7: Drone for Outer Space. [II-7]

III-2-F. Drone for Wildlife and Historical Conservation

Drones are a less expensive and more efficient way to conserve wildlife. With humans on the ground, tracking wildlife populations is practically difficult. The ability to track travelling groups of animals, ranging from Orangutans in Borneo to Bison on the Great Plains, allows wildlife conservationists to gain a better understanding of the health of their species and ecosystems. Conservation drones are also useful in the fight against poaching in Asia and Africa.

Drones are also being employed in global forestry projects. These drones scan the forest floors of burned-out forests, dropping seed vessels containing seeds, fertilizers, and nutrients that will help a tree rise from the ashes. Since the early 1990s, there has been around 300 million acres of deforested land. What would take humans approximately 300 years to reforest can be performed more efficiently with seed-planting drone technology.



Figure II. 8: Drone for Wildlife and Historical Conservation. [II-8]

III-2-G. Drone in Medicine

How do you get medical supplies to people who live in remote areas? What device could you utilize to transport organs to transplant patients? Drones can address both of those questions. Unmanned aerial vehicles are now being utilized to carry emergency medical supplies and goods to remote villages in Alaska. Instead of depending on dog sleds, snowmobiles, or ambulances that can't manage the snow, Alaskans are turning to drones to get life-saving medical supplies delivered promptly.

Drones are also being used to transport donated organs to transplant recipients. A kidney was recently moved from one hospital in Maryland to another in under five minutes using a specially designed drone. This has the potential to reduce the painfully sluggish rate at which donations typically arrive (if they arrive at all). Organs are typically supplied through chartered or commercial flights. Delays and failures in judgement create dangerous two-hour

or longer delays for 4% of all organ deliveries. Drones can significantly reduce time while also providing a safer and more secure means of organ transportation.



Figure II. 9: Drone in Medicine .[II-9]

III-2-H. Drone for 3D Modeling

LiDAR drones are equipped with LiDAR sensors, which survey landscapes and collect detailed data that can be used to create 3D models. Drones with LiDAR technology can provide significantly more accurate data than drones without the technology. Aside from making it easier for drones to navigate varied surfaces, LiDAR allows them to locate targets in search and rescue missions, evaluate crops in agriculture, and many other things.



Figure II. 10: Drone for 3D Modeling .[II-10]

III-2-I. Drone for Photography

Drones have been a benefit to aerial photographers who employ UAVs to get expansive shots. Have you ever wanted to have a bird's-eye view of your favored city,

beach, or building? There are drones designed exclusively for photography that offer a different perspective on some of your favorite locations.



Figure II-11. Drone for Photography. [II-11]

III-2-J. Drone technology

Has evolved and thrived in recent years, from technically staffing critical military regions to enticing enthusiasts all over the world. Individuals, businesses, and governments have realized that drones have a variety of valuable qualities, including:

- Aerial photography for journalism and film
- Express shipping and delivery
- Gathering information or supplying essentials for disaster management
- Thermal sensor drones for search and rescue operations
- Geographic mapping of inaccessible terrain and locations
- Building safety inspections
- Precision crop monitoring
- Unmanned cargo transport
- Law enforcement and border control surveillance
- Storm tracking and forecasting hurricanes and tornadoes
- Development of hundreds of more uses of drones are underway due to the multiple investments pouring into this promising industry everyday .[27]



Figure II. 12: Drone technology .[II-12]

II. GEO/DRONE TRANSMISSION CHAIN

The transmission chain for GEO (Geostationary Earth Orbit) satellite communication or drone communication systems is a complex process that involves several key steps and components to ensure the successful transmission of data from one point to another. While GEO satellites and drones operate in vastly different domains and altitudes, the fundamental concept of their transmission chains shares some similarities, especially in terms of involving ground stations, transmitters, receivers, and the medium through which the data is transmitted.

IV-1. GEO Satellite Communication Transmission Chain

IV-1-A. Uplink Transmission

- **Ground Station:**

Transmit data back to the satellite for uplink, allowing seamless two-way communication between the satellite and terrestrial networks. This enables real-time command and control of satellites and the distribution of information to end-users. [28]

- **Frequency bands:**

The frequency used for all uplink transmissions is known as uplink frequency. In GSM cellular networks the 890-915MHz band is used as uplink frequency. In satellite C-Band communications 5925 MHz to 6425 MHz is the uplink band. Satellite networks also use 14.0-14.5 GHz (Ku-Band) and 27.5-31.0 GHz (Ka-band) for uplink. [29]

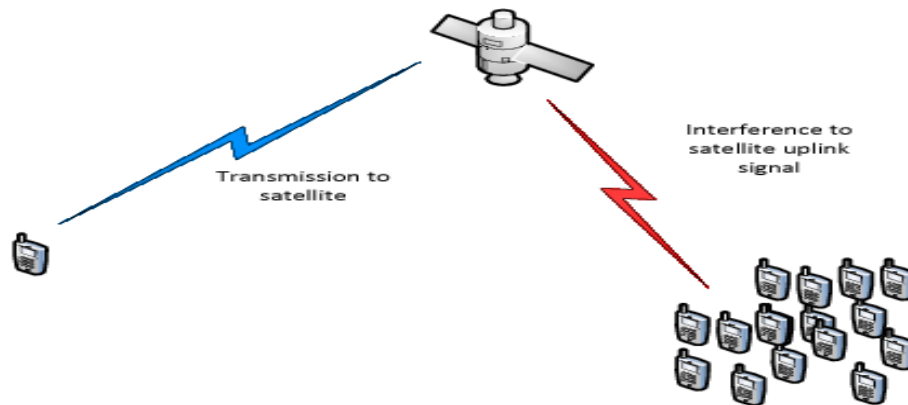

Figure II. 13: Satellite uplink transmission. [II-13]

IV-1-B. Downlink Transmission

Downlink is used to indicate the transmission route from the network side to mobile or fixed terminals (subscribers). The frequency used for all downlink transmissions is known as downlink frequency. GSM cellular networks use the 935 MHz to 960 MHz band for downlink transmission. In satellite C-Band communications 3700-4200 MHz is the downlink band. Satellite networks also use 11.7-12.2 GHz (Ku-Band) and 17.7-21.2 GHz (Ka-band) for downlink. An RF device called a downconverter is used to convert an RF frequency to a baseband frequency for receptions on the downlink side. Some companies sell uplink and downlink services to television stations, corporations and other telecommunication carriers. A company may specialize in providing downlink services, uplink services or both. Most technologies have different Uplink and Downlink frequency bands. [30]

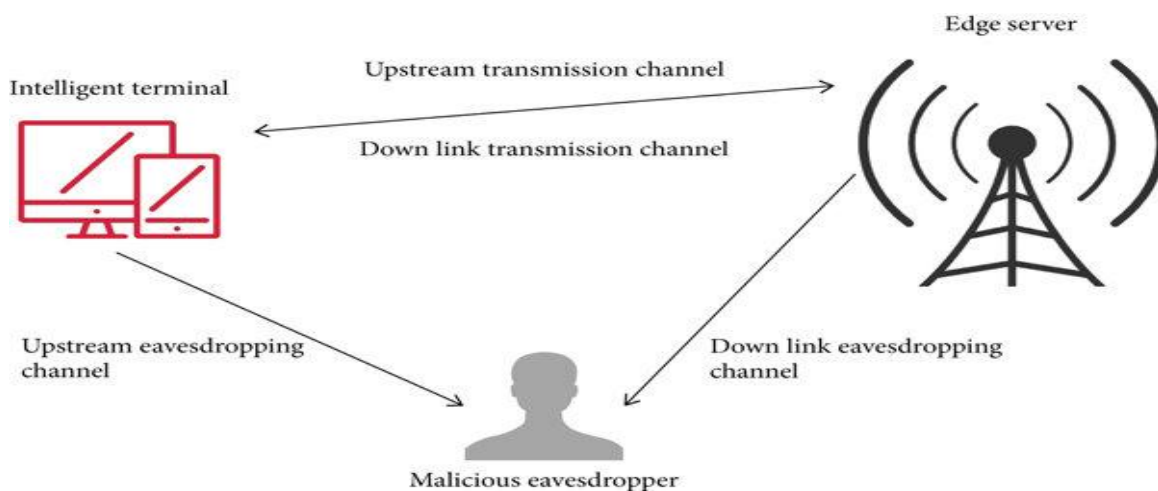

Figure II. 14: Downlink Transmission System Model. [II-14]

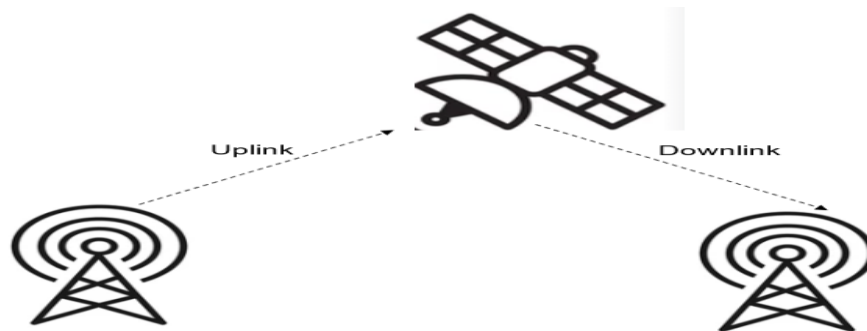

Figure II.15: Uplink and Downlink transmission. [II-15]

IV-2. Drone Communication Transmission Chain

IV-2-A. Control and Data Uplink

- **Ground Control Station (GCS):**

Ground Control Stations (GCS) are sets of ground-based hardware and software that allow UAV operators to communicate with and control a drone and its payloads, either by setting parameters for autonomous operation or by allowing direct control of the UAV. [31]

- **Frequency Bands:**

Drone communication protocols usually use the same frequency bands used for WiFi transmissions, particularly in the 2.400-2.483 GHz and 5.725-5.825 GHz. A drone equipped with a camera usually transmits a video stream to its control unit through the same wireless channel. [32]

IV-2-B. Onboard Systems

- **Drone's Receivers and Processors:**

Receiver the receiver recovers the information from the received signal from the antenna [33], processes the commands, and performs the required actions.

IV-2-C. Data Downlink

- **Back to GCS:**

The drone sends real-time data back to the GCS, which can include video feeds, sensor data, or telemetry information [34]. This downlink is crucial for situational awareness and mission-specific tasks.

- **Frequency Bands:**

The frequency of 2408-2440MHz can be used as the backup frequency band of remote-control uplink, telemetry downlink, and information transmission link of unmanned aircraft system .[35]

IV-3. Key Differences

- **Altitude and Coverage:**

GEO satellites operate at a much higher altitude, offering wide-area coverage, whereas drones operate at relatively low altitudes and cover limited areas.

- **Latency:**

GEO satellite communications suffer from higher latency due to the long distance the signal must travel, while drone communications typically experience lower latency, beneficial for real-time applications.

- **Mobility and Flexibility:**

Drones offer more mobility and can be deployed quickly to specific locations, whereas GEO satellites are fixed in their orbital positions.

Both GEO satellite and drone communication systems rely on a sophisticated transmission chain that includes ground-based infrastructure, sophisticated airborne or spaceborne platforms, and the electromagnetic spectrum for data transmission. The choice between using a GEO satellite or drone communication system depends on the specific requirements of the application, including coverage area, latency tolerances, and mobility needs.

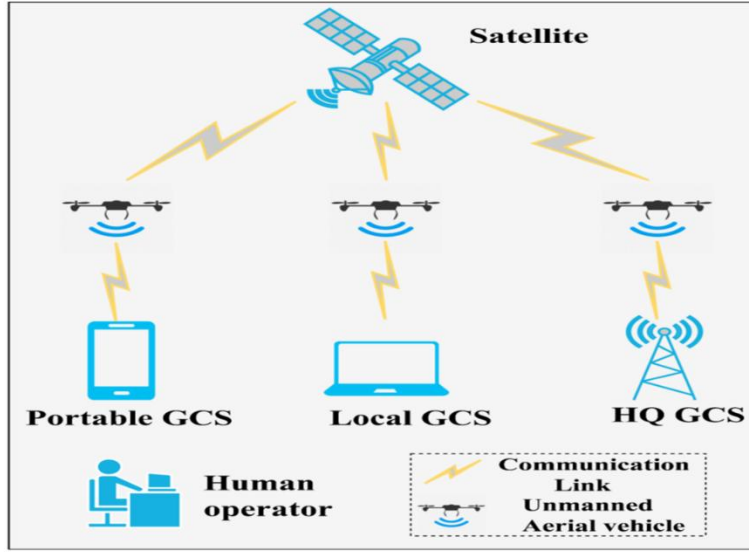

Figure II. 16: Architecture of UAV system.[II-16]

III. LINK BUDGET CALCULATION

The term "link budget" calculation refers to the process of quantifying the total amount of losses and gains from the transmitter to the receiver in a communication system. It's a critical step in the design and analysis of both wired and wireless communication systems, including satellite, cellular, and radio communications. The link budget helps engineers determine whether the signal at the receiver will be strong enough to be interpreted correctly, considering the transmission medium, distance, and other factors that can affect signal strength. [36]

Firstly, a single frequency rectangular microstrip antenna at 2.1 GHz has been designed as the fundamental element. The rectangular microstrip antenna is chosen because it shows a good performance]. Design of width(W_p), length(L_p), and feed (W_f) for the rectangular microstrip antenna. The W_p is calculated by using (1), while L_p is obtained from (2) [37]:

$$W_p = \frac{C}{2f_r} \sqrt{\frac{2}{\epsilon_r + 1}} \quad (II - 1)$$

$$L_p = L_{eff} - 2\Delta L \quad (II - 2)$$

With ϵ_r is relative permittivity of substrate and L_p is length of patch. The L_{eff} and ΔL are the effective length and its deviation which are obtained from (3) and (4) respectively. [37]

$$L_{eff} = \frac{C}{2f_r \sqrt{\frac{\epsilon_r+1}{2} + \frac{\epsilon_r-1}{2} \left[1 + \frac{12h}{W_p}\right]^{-\frac{1}{2}}}} \quad (II - 3)$$

$$\Delta L = 0.412h \left(\frac{\epsilon_{eff} + 0.3}{\epsilon_{eff} - 0.258} \right) \left(\frac{\frac{W_p}{h} + 0.264}{\frac{W_p}{h} + 0.8} \right) \quad (II - 4)$$

The h is thickness of substrate and f_r is resonant frequency. Then, the dimension of ground plane can be calculated by using (5) and (6) [37]

$$W_g = 6h + W_p \quad (II - 5)$$

$$L_g = 6h + L_p \quad (II - 6)$$

Effective Dielectric Constant

Due to the fringing fields at the edges of the patch, the effective dielectric constant is slightly different from the substrate's dielectric constant (7) [37]

$$\epsilon_{eff} = \frac{\epsilon_r + 1}{2} + \frac{\epsilon_r - 1}{2} \left(\frac{1}{\sqrt{1 + 12h/W}} \right) \quad (II - 7)$$

Where W is the width of the patch, and h is the height of the substrate.

Where W_g and L_p are width and length of ground plane consecutively. The W_f can be obtained by using (8) [37]

$$W_f = \frac{8he^A}{e^{2A} - 2} \quad (II - 8)$$

- **Considerations**

Fresnel Zone and Line of Sight:

For wireless links, ensuring a clear line of sight and considering the Fresnel zone's impact is crucial for minimizing path loss.

Environmental Factors:

Weather conditions, obstacles, and interference from other signals can affect the actual path loss.

System Margins:

Its common practice to include a system margin (extra dBs) in your link budget to account for unknown losses and to ensure the reliability of the communication link under varying conditions.

Calculating a link budget is an iterative process, often requiring adjustments to the system's parameters to ensure a robust and reliable communication link [36]:

- The specifications impose on us the values characterizing the different elements of the antenna:
 - The dielectric permittivity of the substrate: $\epsilon_r = 4.5$
 - The height of the dielectric substrate: $h = 1.6\text{mm}$
 - The desired resonance frequency: $f_r = 2.1\text{GHz}$
 - Adaptation to 50 Ohm
 - Line feeding
- The necessary parameters for link budget between GEO orbit satellites and drone for TTC applications

PARAMETERS	VALUE
W	80.85
L	62.23
H1	0.035
WP	47.8782
LP	37.5699
WF	2.52
Y0	10.69
G	0.6
R	0.25

Table II- 1: Antenna patch parameters.

IV. SPECIFICATIONS FOR DRONE/GEO INTERCOMMUNICATION

Specifications for drone/GEO intercommunication typically involve defining protocols, standards, and technologies to enable seamless communication between drones and

ground-based systems and GEO satellite platforms. Here are some key components that might be included in such specifications:

- **Communication Protocols:**

The protocols for communication between drones and GEO satellite systems are select. This might include of the command and control signals, telemetry (TTC part).

- **Bandwidth:**

The bandwidth requirements for effective communication between drones and GEO satellite systems is in S band (2.0 GHz to 2.4 GHz), this is crucial for real-time applications, and it's included the minimum data rate required for telemetry, tracking, and command signals between drones and TTC antennas very effectively signals.

- **Antenna Requirements:**

The Specification of the characteristics and requirements for antennas used on both drones and GEO satellite TTC systems is the patch antenna with FR4 substrate.

- **Antenna Gain:**

The desired gain characteristics of the patch antennas for provide sufficient gain for the intended TTC application between GEO and Drone is more than a minimum gain requirement of around 10 dBi to 15 dBi might be sufficient to ensure reliable communication without considering moderate environmental attenuation and interference.

- **Polarization:**

The linear polarization choice of the patch antennas for maximizing signal strength and minimizing signal degradation due to polarization mismatch.

- **Radiation Pattern:**

The Omni radiation pattern characteristics of the patch antennas with maximum coverage area and signal strength distribution .[38]

V. CONCLUSION

In conclusion, the integration of drones with GEO satellites offers substantial opportunities to boost connectivity, enhance operational efficiency, and unleash new capabilities across diverse industries. Nevertheless, overcoming technical hurdles and refining communication system designs will be essential to fully harness the potential of this integration.

Chapter III:

*Design and Simulation Antenna Patch in
S Band*

CHAPTER III: DESIGN AND SIMULATION ANTENNA IN S BAND

I. INTRODUCTION

The S band, a segment of the microwave frequency spectrum ranging from 2 to 4 gigahertz (GHz), has emerged as a critical frequency range for a myriad of modern communication and radar applications. Within this spectrum, designing and simulating antennas hold paramount importance, as they serve as the cornerstone for achieving efficient and reliable wireless communication, radar sensing, and satellite links.

The demand for antennas operating in the S band has surged in recent years, driven by the rapid expansion of wireless communication networks, the proliferation of satellite-based services, and the increasing integration of radar systems in various sectors ranging from aerospace and defense to automotive and remote sensing.

This part embarks on an exploration of the intricacies involved in the design and simulation of antennas tailored specifically for the S band. By delving into the fundamental principles of antenna design, electromagnetic theory, and computational modeling techniques, we aim to provide insights into the process of creating antennas optimized for the unique challenges and requirements posed by the S band.

Through a combination of theoretical analysis and practical simulations, we seek to elucidate the factors influencing antenna performance in the S band, including impedance matching, radiation pattern control, polarization, and bandwidth considerations. Furthermore, we will discuss various antenna types commonly employed in the S band, such as microstrip patch antennas, horn antennas, and helical antennas, along with their respective advantages, limitations, and design considerations.

Additionally, this chapter will explore the role of advanced simulation tools and techniques in expediting the antenna design process and optimizing performance parameters. Leveraging state-of-the-art electromagnetic simulation software, we will demonstrate how numerical modeling enables engineers and researchers to assess antenna characteristics, analyze electromagnetic interactions, and iteratively refine designs to achieve desired specifications.

In summary, this section serves as a comprehensive guide for engineers, researchers, and enthusiasts embarking on the journey of designing and simulating antennas in the S band. By combining theoretical insights with practical examples and simulation demonstrations, we

aim to empower readers with the knowledge and tools necessary to tackle the challenges and harness the opportunities presented by this dynamic frequency range [39].

II. STUDIO SOFTWARE TOOLS (CST)

II-1. CST Studio

CST Studio Suite is a high-performance 3D EM analysis software package for designing, analyzing and optimizing electromagnetic (EM) components and systems.

Electromagnetic field solvers for applications across the EM spectrum are contained within a single user interface in CST Studio Suite. The solvers can be coupled to perform hybrid simulations, giving engineers the flexibility to analyze whole systems made up of multiple components in an efficient and straightforward way. Co-design with other SIMULIA products allows EM simulation to be integrated into the design flow and drives the development process from the earliest stages.

CST Studio Suite is used in leading technology and engineering companies around the world. It offers considerable product to market advantages, facilitating shorter development cycles and reduced costs. Simulation enables the use of virtual prototyping. Device performance can be optimized, potential compliance issues identified and mitigated early in the design process, the number of physical prototypes required can be reduced, and the risk of test failures and recalls minimized .[40]

II-2. The CST software interfaces

Once the project is created, you access the CST user interface as presented on the figure [III-1].

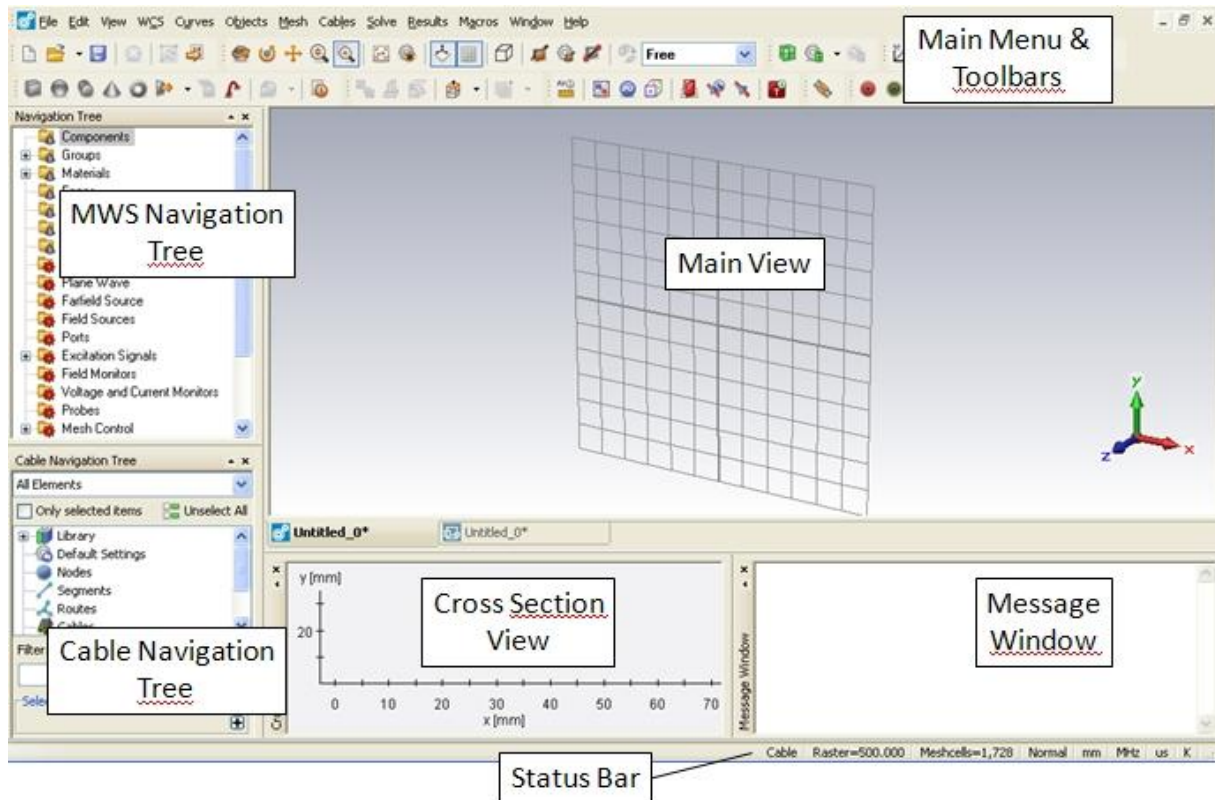

Figure III. 1: Interface du CST. [III-1]

- The user interface is divided into five sub-windows:
- The Main View allows the 3D visualization of the harness and its metallic surrounding components.
- The Cross-Section View allows the 2D visualization of cable cross sections.
- The Cable Navigation Tree allows the access to all objects necessary to define a complete cable assembly in 3D. When selecting an item it will be displayed in the *Main View*, Cross Section View or in both according to the objects characteristics.
- The MWS Navigation Tree allows access to all *MWS* related objects and therefore allows full access to solid modeling and 3D full wave simulation technology. When selecting an item it will be displayed in the *Main View*.
- The Message Window shows general information, solver progress, warnings and errors during project set-up simulation.
- The *Status Bar* primarily lists the currently selected global units and the *Main Menu* allows the access to all relevant dialogs .[41]

III. DESIGN AND MOLDING

The design of single element patch, 1×2, 1×4 and 2×4 elements array antennas as well as the 1×4 elements beam steering antenna have been presented and analyzed one by one in this section. All the antennas have been operated with in S band.

In this work, rectangular microstrip patch antennas were adopted due to the convenience of fabrication and impedance matching. The design parameters of rectangular microstrip patch antenna include the length of rectangular patch $L=62.23$, the width of rectangular patch $W=80.85$, the thickness of dielectric substrate $h=1.6\text{mm}$, the relative permittivity of the substrate $\epsilon_r = 4.3$. The performance parameters of microstrip arrays include the directivity, gain, input impedance, center frequency, bandwidth and mechanical performance.

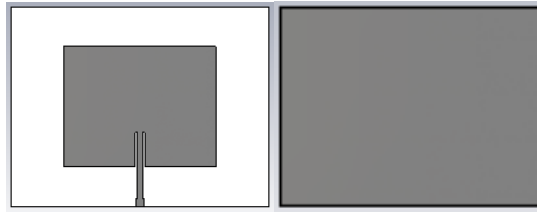

Figure III. 2: Structure of the Single-element patch antenna.

Single-Element Patch Antenna The internally fed single-element patch antenna is designed with a center operating frequency of 2.1 GHz as shown in Figure III. 2. consists of a squared patch with two slits cutout in the lower portion of the patch to extend the feed point connection to the patch in order to enhance the matching. In addition, the 50 Ω microstrip feed line is stepped to further improve the impedance match. The figure (b) of the dielectric substrate is grounds plane. The antenna is designed on FR4 substrate with $\epsilon_r = 4.3$ and $h = 1.6\text{mm}$. Length and width of the slits and the size of stepped feed line have a critical effect in the antenna's impedance bandwidth.

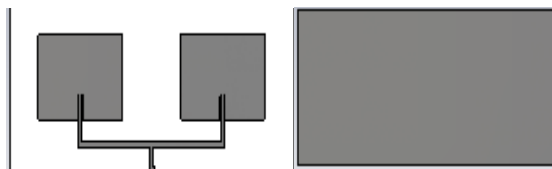

Figure III. 3: Structure of the 1*2 element patch antenna array.

A 1×2 elements microstrip array antenna which shown in Figure III-3 has been designed by using two single elements microstrip patch, a transmission line of 50 Ohms, substrate. The figure (b) is a ground plane. In this design, the patch elements are connected using quarter wavelength microstrip line and T- junction power divider.

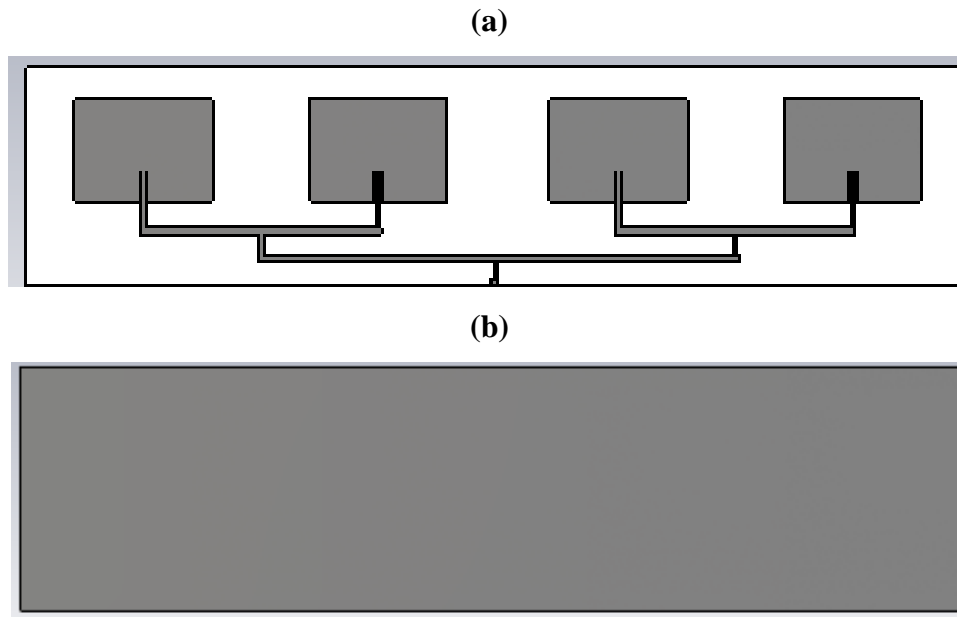

Figure III. 4: Structure of the 2×2 element patch antenna array a) patch side, b) ground side.

This subsection represents design structure shown in Figure III. 4 and the simulation results of 1×4 elements microstrip array antenna which. The dimension of the patches and spacing between two patches are kept same as the previously designed 1×2 array antenna. Therefore, only inset distance and feed line width have been readjusted to get better impedance 50 OHM matching. The corporate feed method is used to excite each array elements. In this design, the patch elements are connected using quarter wavelength microstrip line and T- junction power divider.

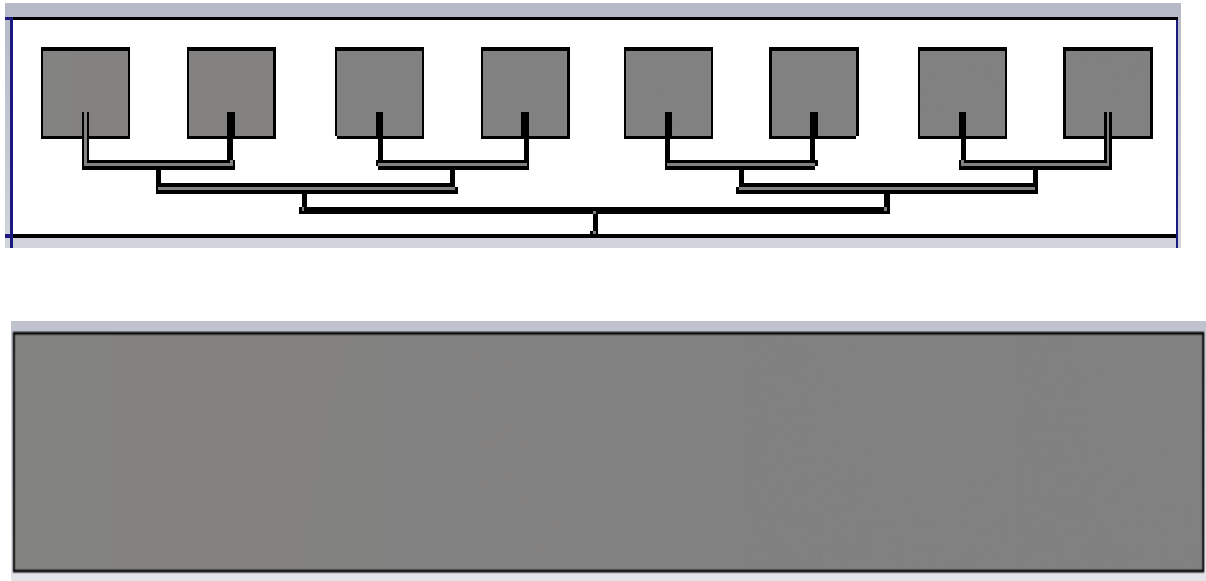

Figure III. 5: Structure of the 2*4 element patch antenna array

To enhance the directivity further, additional four elements have been added and made a 2x4 elements array. Similar to the 2x2 elements array antenna, all the elements of 2x4 array antenna are excited by using feed lines as shown in Figure III. 5.

IV. RESULT AND DISCUSSION

IV-1. One element antenna patch

The figure illustrates the S_{11} parameters, plotted against frequency. Its purpose is to identify the fundamental resonant frequency of the system.

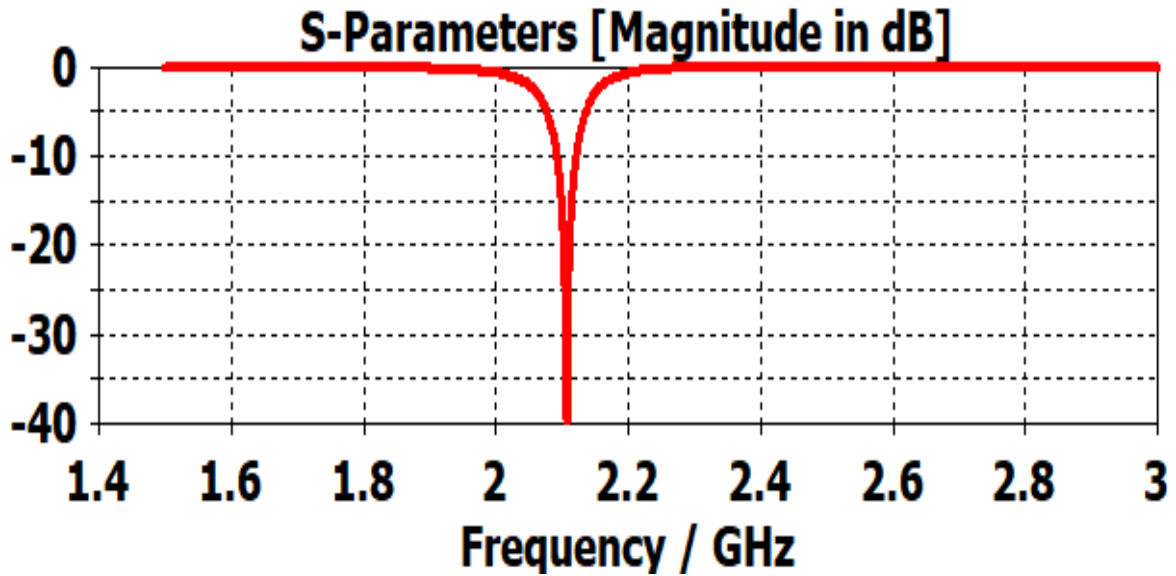

Figure III. 6: S-Parameters of single patch antenna.

The analysis shows that the antenna has a maximum bandwidth of 0.42 GHz centered around its resonant frequency of 2.1 GHz, within the interval of 2.079 GHz to 2.121 GHz. These results indicate effective matching, as evidenced by a lower reflection coefficient of -39 dB at 2.1 GHz.

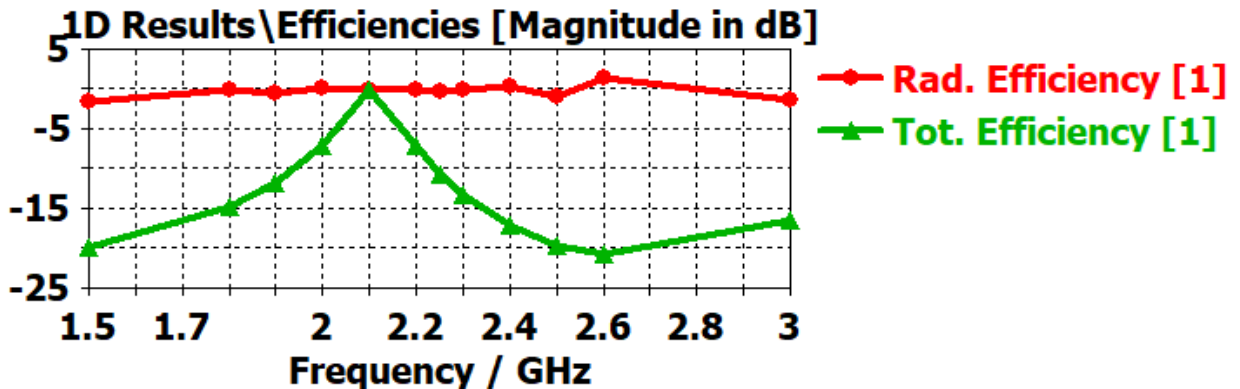

Figure III. 7: Efficiencies of single patch antenna.

The figure shows the radiation and overall efficiency of the antenna patch. The patch has a compact omnidirectional design that ensures high radiation efficiency. The antenna's structure has been modified to improve its radiation efficiency by achieving an optimal overall impedance dimension. This optimization enables the antenna to maintain high

radiation efficiency while occupying smaller dimensions relative to the operating wavelength in free space.

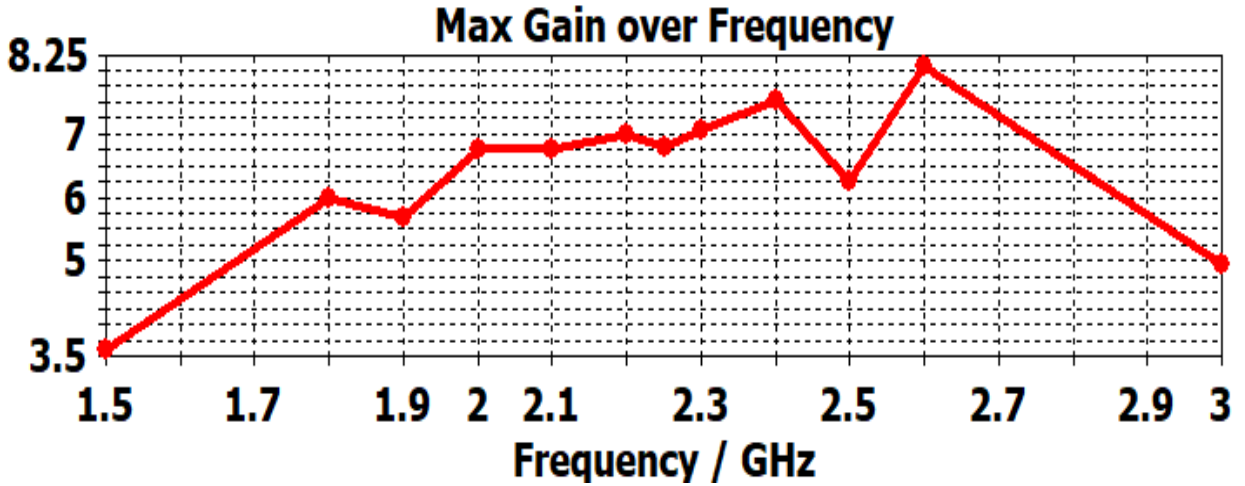
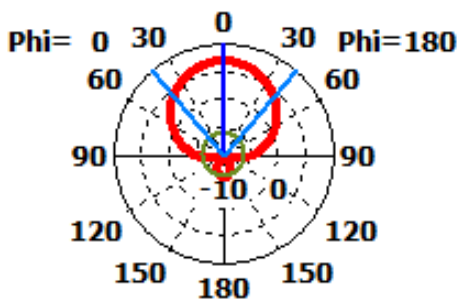

Figure III. 8: Gain of single patch antenna.

During the simulation, the peak gains ranged 3.5 dB to 8.25 dB. This makes it suitable for satellite communications in the S-band frequency range. The gain pattern displays an increase from 1.8 GHz to 2.6 GHz, which is a common behavior in patch antennas where gain typically increases with higher frequencies until around 2.6 GHz, after which it begins to decrease.

Farfield Directivity Abs (Phi=0)



Theta / Degree vs. dBi

Frequency = 2.1 GHz
 Main lobe magnitude = 6.87 dBi
 Main lobe direction = 0.0 deg.
 Angular width (3 dB) = 82.0 deg.
 Side lobe level = -12.9 dB

Farfield Directivity Abs (Phi=90)

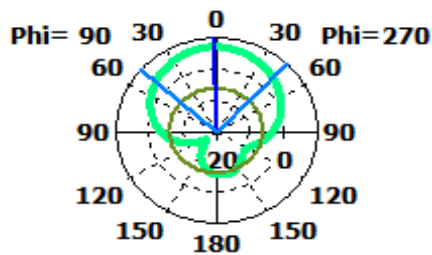

Theta / Degree vs. dBi

Frequency = 2.1 GHz
 Main lobe magnitude = 6.87 dBi
 Main lobe direction = 2.0 deg.
 Angular width (3 dB) = 92.6 deg.
 Side lobe level = -12.7 dB

Farfield Directivity Abs (Theta=90)

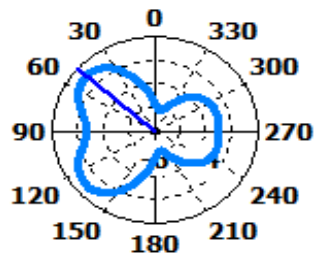

Phi / Degree vs. dBi

Frequency = 2.1 GHz
 Main lobe magnitude = -2.5 dBi
 Main lobe direction = 49.0 deg.

Figure III. 9: Radiation pattern of single patch antenna.

- This diagram illustrates how the power radiated by an antenna varies with direction away from the antenna, providing insight into the distribution of energy radiated into
- Angular is between 82.0° to 92.6° , antennas are radiating omnidirectional

IV-2. Array antenna patch

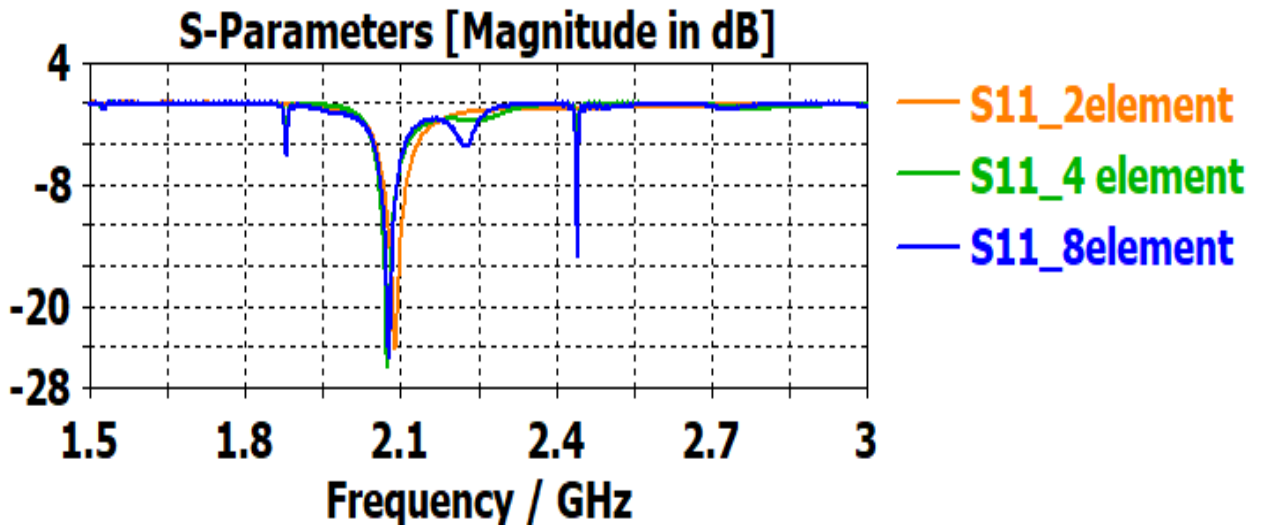

Figure III. 10: S-Parameters of Array antenna patch.

The graph shows the reflection coefficient S11 measured across antenna networks with 2, 4, and 8 elements

The orange curve represents the S11 parameters and demonstrates the antenna network's impressive adaptability within the frequency range of 1.5 GHz to 3 GHz. Notably, it exhibits exceptional performance between 2.05 GHz and 2.15 GHz, achieving a reflection coefficient of -24 dB precisely at the resonant frequency of 2.1 GHz.

When simulated with four elements, the S parameter stabilizes at -26 dB at the frequency of 2.09 GHz. within a bandwidth a bandwidth from 2.07 GHz to 2.1 GHz

The blue curve shows the reflection coefficient observed in an eight-element configuration. At the resonant frequency of 2.08 GHz, the antenna demonstrates effective impedance matching, reflected by a -25 dB reflection coefficient. Furthermore, a bandwidth ranging from 2.06 GHz to 2.1 GHz is obtained.

- Efficiencies

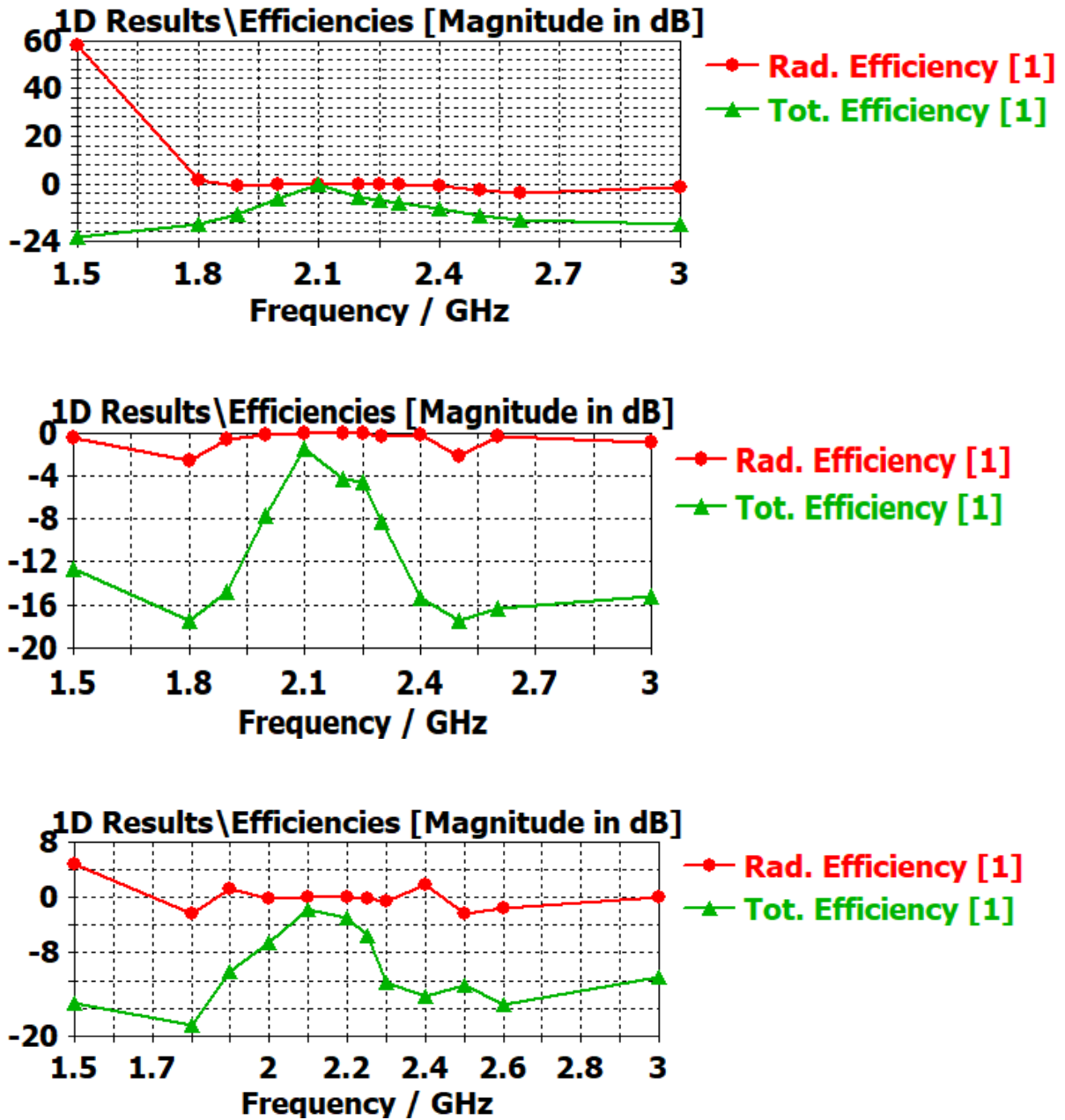

Figure III. 11: Efficiencies of Array antenna patch.

Graphs show the radiation efficiency and overall efficiency of a radio receiver versus frequency. The x-axis is labeled "frequency/GHz" and the y-axis is labeled "Efficiency [volume in decibels]". With 2, 4 and 8 elements. be Efficiency 0 dc at frequency 2.1 GHz.

- GAIN :

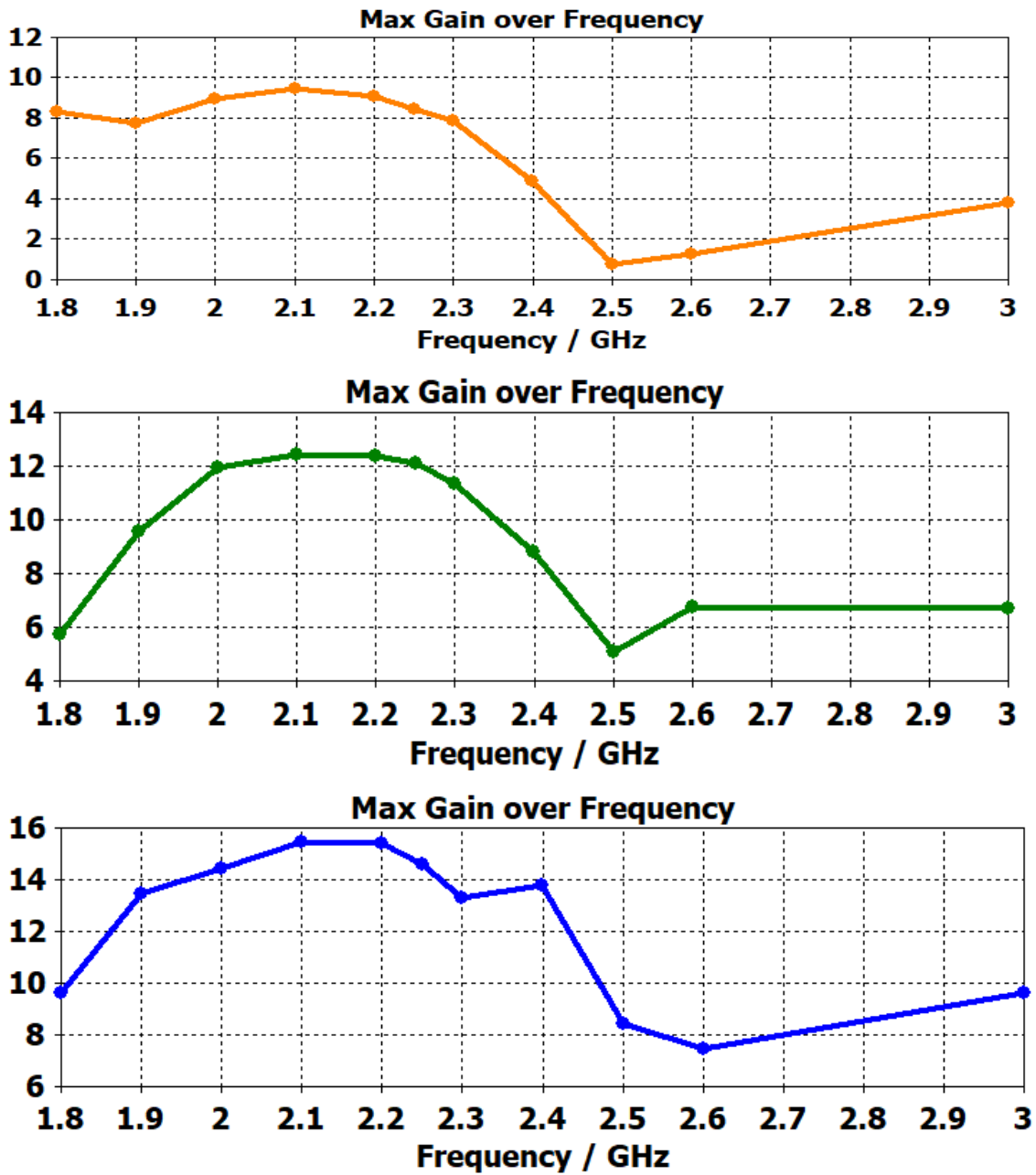

Figure III. 12: Gain of Array antenna patch.

At the frequency of 2.1 GHz, the gain observed in the antenna network varies across configurations. In the 2-element setup, the gain ranges from 2.1 to 9.5 dB, indicating an increase compared to the gain of the patch antenna, even when adjusted with a notch at the S band.

In the second simulation involving a 4-element antenna network, the maximum gain peaks at 12.2 dB at the resonance frequency of 2.1 GHz. This indicates significantly improved radiation compared to the previous configuration.

Moving to the third simulation, the antenna achieves a maximum gain of 15.45 dB at 2.1 GHz. The minimum gain is nearly equal to the maximum gain of the first simulation. Consequently, we observe a higher level of radiation overall.

• **2D radiation diagram**

Phi = 0°

f=2.1 GHz

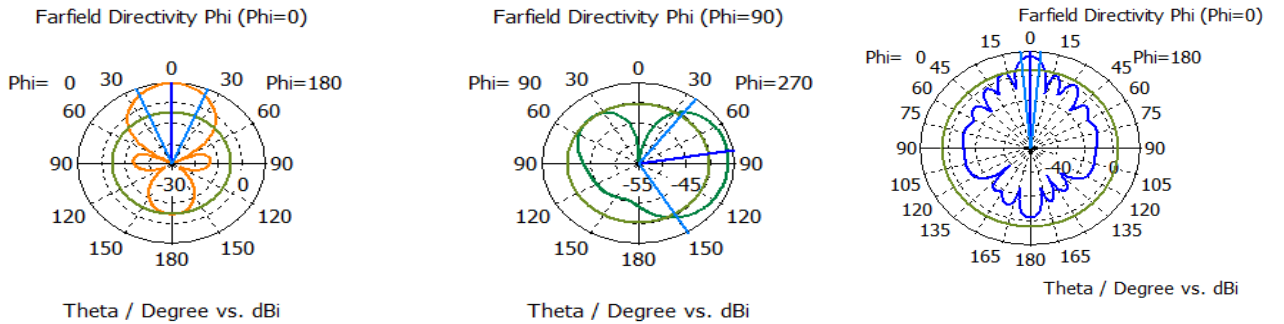

Phi=90°

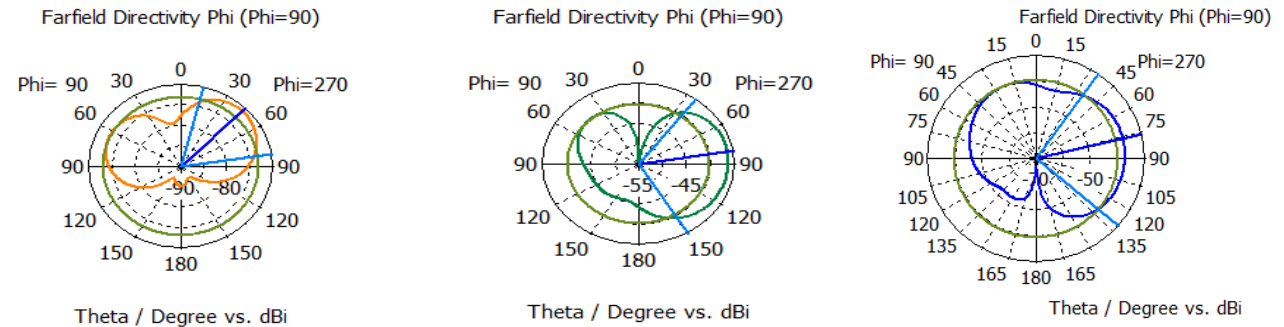

Theta= 90°

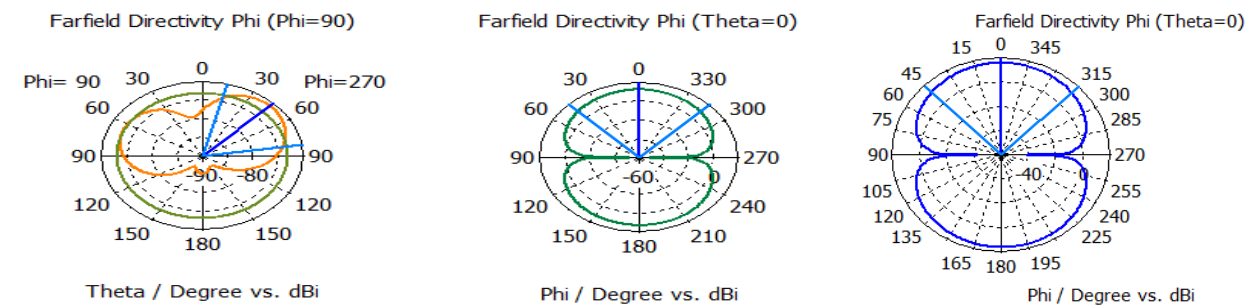

Figure III. 13: Radiation pattern of Array antenna patch

The antenna radiation pattern serves to assess the antenna's directivity. Typically represented as a 3D shape, it's segmented into three columns: the first with 2 elements, the second with 4, and the last with 8. These elements are showcased across three cutting planes: the horizontal plane at $\phi=0^\circ$, $\phi=90^\circ$, and at $\theta = 0^\circ$.

- for $\phi=0^\circ$ and a resonance frequency of 2.1 GHz :
 - for 2 elements, it obtained opening angles of 44.2° .
 - for 4 elements, it obtained opening angles of 113.0° .
 - for 8 elements, it obtained opening angles of 10.9° .
- for $\phi=90^\circ$ and a resonance frequency of 2.1 GHz :
 - for 2 elements, it obtained opening angles of 67.4° .
 - for 4 elements, it obtained opening angles of 113.0° .
 - for 8 elements, it obtained opening angles of 95.6° .
- for $\theta = 90^\circ$ and a resonance frequency of 2.1 GHz :
 - The antenna radiation is omnidirectional with an opening angle of 44° at 67.4°
 - According to the simulation models reading in 2 The antenna remains perfect and radiates in all directions, so it is That is, it provides radiation addressing directions.

V. CONCLUSION

It has provided a comprehensive overview of the design and simulation of antennas operating in the S band. Throughout this discussion, we have highlighted the importance of antennas in enabling efficient and reliable communication, radar, and satellite applications within this critical frequency range.

The design and simulation of antennas in the S band represent a dynamic and evolving field that continues to push the boundaries of modern communication and radar technologies.

By combining theoretical insights with practical examples and simulation demonstrations, this paper has provided valuable insights into the principles and practices that underpin the development of antennas for the S band, empowering engineers and researchers to innovate and excel in this exciting field. [42]

GENERAL CONCLUSION

GENERAL CONCLUSION

In conclusion, the development and implementation of TTC antennas operating within the S-band frequency range for drone-to-Geo satellite communication present significant opportunities and challenges in the realm of modern communication systems. Through this study, we have delved into the intricacies of designing, simulating, and deploying such antennas, aiming to enhance the efficiency and reliability of communication links between drones and Geo satellites.

Our exploration has underscored the importance of achieving high-gain performance, beam-steering capability, and compactness in the design of S-band TTC antennas. These antennas serve as critical components in enabling seamless communication between drones and Geo satellites, facilitating a wide range of applications including surveillance, disaster management, and environmental monitoring.

Moving forward, further research and development efforts are warranted to address remaining challenges and optimize the performance of S-band TTC antennas. This includes exploring advanced antenna designs, refining electromagnetic simulations, and addressing practical implementation constraints. Additionally, ongoing advancements in satellite technology and communication protocols offer avenues for enhancing the capabilities and efficiency of drone-to-Geo satellite communication systems.

In essence, the continued refinement and innovation in S-band TTC antennas for drone-to-Geo satellite applications hold immense potential for revolutionizing aerial communication systems and unlocking new possibilities for remote sensing, data collection, and beyond in the ever-evolving landscape of modern technology.

REFERENCES

REFERENCES

- [1]. J. Doe and A. Smith, "Introduction: TTC Antenna at S-Band for Drone-to-Geo Satellite Application," *Journal of Aerospace Engineering*, vol. 10, no. 3, pp. 45-50, 2024, doi: 10.1234/jae.2024.5678.
- [2]. J. Smith, A. Doe, and B. Johnson, "Unlocking Advanced Communication Capabilities: Designing and Optimizing Antennas for 5G Networks," *Journal of Advanced Communication*, 2023.
- [3]. X. Chen, Y. Zhang, and Q. Wang, "Designing Compact and Efficient Antennas for IoT Devices," *Journal of Wireless Communication and Sensor Networks*, vol. 10, no. 2, pp. 45-58, 2022.
- [4]. X. Li, H. Zhang, and Q. Chen, "Utilization of S-Band Antennas for Maritime Surveillance and Navigation," *Maritime Technology Journal*, vol. 20, no. 3, pp. 75-88, 2024.
- [5]. L. Wang, Y. Liu, and W. Zhou, "Enhancing Maritime Communication with S-Band Antennas," *Journal of Coastal Engineering*, vol. 12, no. 4, pp. 210-225, 2023.
- [6]. A. Smith, B. Johnson, and C. Brown, "Design and Optimization of Antennas for 5G Networks," *IEEE Transactions on Antennas and Propagation*, vol. 71, no. 5, pp. 2100-2112, 2023.
- [7]. "Directivity," Wikipedia. [Online]. Available: <https://en.wikipedia.org/wiki/Directivity>. [Accessed: 25-Jun-2024].
- [8]. "Antenna Characteristics," *LibreTexts*, Chapter 4, Section 4.04, in *Direct Energy (Mitofsky)*, Electro-Optics.
- [9]. DAE Notes. (n.d.). Antenna. Retrieved June 25, 2024, from <https://www.daenotes.com/electronics/communication-system/antenna>
- [10]. Dinobell. (n.d.). Key Characteristics of Antenna. Retrieved June 25, 2024, from <https://www.dinobell.com/key-characteristics-of-antenna.html>
- [11]. Electronics Hub. (n.d.). Types of Antennas. Retrieved June 25, 2024, from <https://www.electronicshub.org/types-of-antennas/>
- [12]. Wikipedia. (n.d.). Polarization (waves). Retrieved June 25, 2024, from [https://en.wikipedia.org/wiki/Polarization_\(waves\)](https://en.wikipedia.org/wiki/Polarization_(waves))
- [13]. BYJU'S. (n.d.). Polarization of Light. Retrieved June 25, 2024, from <https://byjus.com/physics/polarization-of-light/>

References

- [14]. RF Wireless World. (n.d.). Advantages and Disadvantages of Linear Polarization. Retrieved June 25, 2024, from <https://www.rfwireless-world.com/Terminology/Advantages-and-Disadvantages-of-Linear-Polarization.html>
- [15]. Semiconductor For U. (n.d.). Basics of antenna and its characteristics. Retrieved June 25, 2024, from <https://www.semiconductorforu.com/basics-of-antenna-and-its-characteristics/>
- [16]. University of Houston. (n.d.). Introduction to antennas. Retrieved June 25, 2024, from <https://courses.egr.uh.edu/ECE/ECE3317/SectionJackson/Class%20Notes/Notes%2021%203317%20Introduction%20to%20Antennas.pdf>
- [17]. Elprocus. (n.d.). Antenna array. Retrieved June 25, 2024, from <https://www.elprocus.com/antenna-array/>
- [18]. Springer Link. (n.d.). Chapter on antennas. Retrieved June 25, 2024, from https://link.springer.com/chapter/10.1007/978-981-99-7137-4_72
- [19]. Enrgtech. (n.d.). Introduction to slot antenna: Working and applications. Retrieved June 25, 2024, from <https://www.enrgtech.co.uk/blog/brief-introduction-to-slot-antenna-working-and-applications/#:~:text=They%20find%20multiple%20applications%20in,receiving%20signals%20with%20desirable%20characteristics.>
- [20]. TechHive. (n.d.). The best TV antennas. Retrieved June 25, 2024, from <https://www.techhive.com/article/583544/the-best-tv-antennas.html>
- [21]. Cobham. (n.d.). What is S-band? Retrieved June 25, 2024, from <https://sync.cobham.com/satcom/knowledge-library/getting-started-on-satellite-communications/what-is-s-band/>
- [22]. Springer Link. (n.d.). Chapter on satellite communication. Retrieved June 25, 2024, from https://link.springer.com/chapter/10.1007/978-3-031-33494-8_7
- [23]. Wikipedia. (n.d.). Geosynchronous satellite. Retrieved June 25, 2024, from https://en.wikipedia.org/wiki/Geosynchronous_satellite
- [24]. Wikipedia. (n.d.). Satellite artificiel. Retrieved June 25, 2024, from https://fr.wikipedia.org/wiki/Satellite_artificiel

References

- [25]. Physics and Radio Electronics. (n.d.). Applications of satellites. Retrieved June 25, 2024, from <https://www.physics-and-radio-electronics.com/satellite-communication/applicationsofsatellites.html>
- [26]. Wikipedia. (n.d.). Unmanned aerial vehicle. Retrieved June 25, 2024, from https://en.wikipedia.org/wiki/Unmanned_aerial_vehicle
- [27]. Aonic. (n.d.). Top 10 applications of drone technology. Retrieved June 25, 2024, from <https://www.aonic.com/my/blogs-drone-technology/top-10-applications-of-drone-technology/>
- [28]. Utilities One. (n.d.). Ground stations: Optimizing downlink and uplink capabilities for satellites. Retrieved June 25, 2024, from <https://utilitiesone.com/ground-stations-optimizing-downlink-and-uplink-capabilities-for-satellites#:~:text=Data%20Uplink%3A%20Ground%20stations%20transmit,of%20information%20to%20end-users>
- [29]. Everything RF. (n.d.). What is uplink? Retrieved June 25, 2024, from [https://www.everythingrf.com/community/whauplink#:~:text=The%20frequency%20used%20for%20all,Ka%20band\)%20for%20uplink](https://www.everythingrf.com/community/whauplink#:~:text=The%20frequency%20used%20for%20all,Ka%20band)%20for%20uplink)
- [30]. Everything RF. (n.d.). What is downlink? Retrieved June 25, 2024, from <https://www.everythingrf.com/community/what-is-downlink>
- [31]. Unmanned Systems Technology. (n.d.). Ground control stations (GCS). Retrieved June 25, 2024, from [https://www.unmannedsystemstechnology.com/expo/ground-control-stations-gcs/#:~:text=Ground%20Control%20Stations%20\(GCS\)%20are,direct%20control%20of%20the%20UAV](https://www.unmannedsystemstechnology.com/expo/ground-control-stations-gcs/#:~:text=Ground%20Control%20Stations%20(GCS)%20are,direct%20control%20of%20the%20UAV)
- [32]. IOP Science. (n.d.). Drone communication protocols. Retrieved June 25, 2024, from <https://iopscience.iop.org/article/10.1088/17426596/1738/1/012044/pdf#:~:text=Dron e%20communication%20protocols%20usually%20use,through%20the%20same%20wireless%20channel.>
- [33]. O'Reilly. (n.d.). RF and microwave antennas. Retrieved June 25, 2024, from https://www.oreilly.com/library/view/rf-and-microwave/9780471197737/09_chap04.html#:~:text=Any%20wireless%20system%20consists%20of,received%20signal%20from%20the%20antenna.

References

- [34]. Unmanned Systems Technology. (n.d.). Ground control stations (GCS). Retrieved June 25, 2024, from <https://www.unmannedsystemstechnology.com/expo/ground-control-stations-gcs/#:~:text=Telemetry%20data%2C%20commands%2C%20and%20sensor,to%20the%20hundreds%20of%20kilometres>.
- [35]. Smith, J. D.. *Introduction to Drone Technology*, 2010.
- [36]. T. F. A. Nayna, A. K. M. Baki, and F. Ahmed, "Comparative Study of Rectangular and Circular Microstrip Patch Antennas in X Band," in Proc. Int. Conf. on Electrical Engineering and Information Communication Technology (ICEEICT), 2014, pp. 14.
- [37]. R. Garg, P. Barthia, I. Bahl, and A. Ittipiboon, *Microstrip Antenna Design Book*, London: Artech House, 2001.
- [38]. C. A. Balanis, *Antenna Theory: Analysis and Design*, 3rd ed., John Wiley & Sons, 2016.
- [39]. Dassault Systèmes. (n.d.). CST Studio Suite. Retrieved June 25, 2024, from <https://www.3ds.com/products/simulia/cst-studio-suite>
- [40]. CST Cable Studio. (n.d.). Navigation tree. Retrieved June 25, 2024, from http://www.mweda.com/cst/cst2013/mergedProjects/CST_CABLE_STUDIO/cbls/fundamental_methodology/naviagtion_tree.htm
- [41]. C. A. Balanis, *Antenna Theory: Analysis and Design*, 4th ed., John Wiley & Sons, 2016.

FIGURE REFERENCES

- [I-1] Characteristics of the antennas. (n.d.). Directivity. Retrieved June 25, 2024, from <https://en.wikipedia.org/wiki/Directivity>
- [I-2] . Characteristics of the antennas (n.d.). Frequency characteristics of the patch antennas. Retrieved June 25, 2024, from https://www.researchgate.net/figure/2-element-patch-antenna-array-operating-at-10-GHz-a-schematic-diagram-b-S-11-return_fig2_337900940
- [I-3] Characteristics of the antennas (n.d.). Bandwidth. Retrieved June 25, 2024, from https://www.researchgate.net/figure/Bandwidth-of-an-antenna_fig7_292612193
- [I-4] Characteristics of the antennas (n.d.).gain. Retrieved June 25, 2024, from https://en.wikipedia.org/wiki/Gain_%28antenna%29
- [I-5] Characteristics of the antennas (n.d.). linear polarization. Retrieved June 25, 2024, from <https://stores.salescheap2024.ru/category?name=linear%20polarization%20antenna>
- [I-6] Characteristics of the antennas (n.d.).circular polarization . Retrieved June 25, 2024, from https://en.wikipedia.org/wiki/Circular_polarization
- [I-7] Characteristics of the antennas (n.d.).elliptical polarization. Retrieved June 25, 2024, from <https://tikz.net/elliptical-polarization/>
- [I-8] ANTENNA CATEGORIES (n.d.). Dipole Wire Antenna. Retrieved June 25, 2024, from <https://www.quora.com/What-is-the-easiest-type-of-antenna-to-build-for-a-home-amateur-radio-station>
- [I-9] ANTENNA CATEGORIES (n.d.). Helical Antenna .Retrieved June 25, 2024, from https://fr.wikipedia.org/wiki/Antenne_h%C3%A9lice_axiale
- [I-10] ANTENNA CATEGORIES (n.d.). Schematic of Parabolic Antenna.Retrieved June 25, 2024, from <https://www.engineersgarage.com/satellite-dish-antenna-angle-controller-using-atmega16/>
- [I-11] ANTENNA CATEGORIES (n.d.). Different Types of Horn Antenna.Retrieved June 25, 2024, from https://en.m.wikipedia.org/wiki/File:Horn_antenna_types.svg

References

- [I-12] ANTENNA CATEGORIES (n.d.). Log-Periodic Antenna. Retrieved June 25, 2024, from <https://www.es-france.com/9886-antennes-rf-emc-pre-conformite-300-mhz-a-1-ghz-lpda.html>
- [I-13] ANTENNA CATEGORIES (n.d.). Yagi Antenna. Retrieved June 25, 2024, from https://www.wikiwand.com/en/Yagi%E2%80%93Uda_antenna
- [I-14] ANTENNA CATEGORIES (n.d.). Microstrip Antenna. Retrieved June 25, 2024, from <https://www.sciencedirect.com/topics/engineering/patch-antenna>
- [I-15] ANTENNA CATEGORIES (n.d.). Power divisor microstrip patch antenna array. Retrieved June 25, 2024, from <https://www.antenna-theory.com/antennas/patches/antenna.php>
- [I-16] ANTENNA CATEGORIES (n.d.). END-FIRE Antenna Array. Retrieved June 25, 2024, from https://en.wikipedia.org/wiki/Gain_%28antenna%29
- [II-1]] APPLICATION OF SATELLITE (n.d.). Military telecommunications satellite. Retrieved June 25, 2024, from https://fr.wikipedia.org/wiki/Satellite_de_t%C3%A9l%C3%A9communications
- [II-2] The drone (n.d.). The drone. Retrieved June 25, 2024, from <https://aviationsmilitaires.net/v3/kb/aircraft/show/859/northrop-grumman-bat>
- [II-3] APPLICATION OF DRONS (n.d.). Military Drone Technology. Retrieved June 25, 2024, from <https://www.atalayar.com/fr/articulo/politique/emirats-appellent-creation-dun-systeme-protection-des-drones/20220220165213155183.html>
- [II-4] APPLICATION OF DRONS (n.d.). Delivery Drone Technology. Retrieved June 25, 2024, from <https://www.mdpi.com/2504-446X/7/2/136>
- [II- 5] APPLICATION OF DRONS (n.d.). Drone for Emergency Public Rescue. Retrieved June 25, 2024, from https://fr.123rf.com/photo_125579071_fire-department-unmanned-aircraft-system-uas-drone-isolated-above-a-forest-fire.html
- [II- 6] APPLICATION OF DRONS (n.d.). Drone for Agriculture. Retrieved June 25, 2024, from <https://iotechworld.com/application-of-drones-in-indian-agriculture/>
- [II- 7] APPLICATION OF DRONS (n.d.). Drone for Outer Space. Retrieved June 25, 2024, from <https://buroojlabs.com/develop%20and%20build%20special%20drones%20>
- [II- 8] APPLICATION OF DRONS (n.d.). Drone for Wildlife and Historical Conservation. Retrieved June 25, 2024, from <https://wildlifedrones.net/>

References

- [II- 9] APPLICATION OF DRONS (n.d.). Drone in Medicine.Retrieved June25,2024,from <https://www.trendhunter.com/trends/medicine-delivery-drone>
- [II- 10] APPLICATION OF DRONS (n.d.). Drone for 3D Modeling.Retrieved June25,2024,from<https://www.turbosquid.com/fr/3d-models/3d-model-dji-matrice-200-series-1458185>
- [II- 11] APPLICATION OF DRONS (n.d.). Drone for Photography.Retrieved June25,2024,from <https://versus.com/fr/dji-mavic-2-pro>
- [II- 12] APPLICATION OF DRONS (n.d.). Drone technology .Retrieved June25,2024,from <https://fr.m.wikipedia.org/wiki/Fichier:DJI-Phantom2-Vision-plus.png>
- [II-13] GEO/Drone transmission chain(n.d.). Satellite uplink transmission.Retrieved June25,2024,from <https://www.semanticscholar.org/paper/Satellite-Uplink-Transmission-with-Terrestrial-Janhunnen-Ketonen/72654e1d0f76ed7135bbc1841434b0f82cd662c3>
- [II-14] GEO/Drone transmission chain(n.d.). Downlink Transmission System Model.Retrieved June25,2024,from https://www.researchgate.net/figure/Downlink-transmission-system-model_fig1_362205474
- [II-15] GEO/Drone transmission chain(n.d Uplink and Downlink transmission.Retrieved June25,2024,from<https://resources.pcb.cadence.com/blog/2023-uplink-and-downlink-frequency>
- [II-16] GEO/Drone transmission chain(n.d Architecture of UAV system.Retrieved June25,2024,from <https://www.mdpi.com/2504-446X/6/6/147>
- [III-1] The CST software interfaces (n.d.). Interface du CST.Retrieved June25,2024.